



SELF-CLINCHING  
STUDS AND  
PINS

BULLETIN



FH

# SELF-CLINCHING STUDS AND PINS

**FH (flush-head) Studs** are installed by placing them in punched or drilled holes in the sheets and squeezing into place with any standard press. The squeezing action embeds the head of the stud into the sheet. The metal displaced by the head flows smoothly and evenly around the ribs and into the annular groove – creating a flush-head assembly and securely locking the stud into the sheet with high torque-out and pushout resistances. (See page FH-4). Also available unthreaded on special order. (See page FH-5)

**TFH (non-flush) Studs** are for sheets as thin as .020 inches / 0.51 mm. They may also be used in thicker sheets where flush head studs are not required. TFH studs are installed in the sheets in the same manner as flush-head studs; however, different punches and anvils are required. When installed, the TFH stud will be securely locked into the thin sheet with ample torque-out and pushout resistances. The stud head will not be flush but will project above the sheet surface approximately .025 in. / 0.64 mm. (See page FH-6)

**HFH (high-strength) Studs** replace weld studs with easier installation at lower costs. The large stud head which projects above the sheet material distributes the axial tightening force over a large area thereby improving pull through resistance. (See page FH-7)

**HFHB (BUSBAR®) Studs** are ideal for applications which demand superior electrical/mechanical attachment points. Phosphor bronze studs offer twice the conductivity of carbon steel studs. (See page FH-7)

**FHL (low-displacement head) Studs** install closer to the edge of a sheet than standard studs without causing that edge to bulge. Depending on thread size, Type FHL studs can be installed from 25% to 50% closer to the edge of a sheet than standard self-clinching studs. (See page FH-8)

**FH4 & FHP (flush-head) Studs for Stainless Steel** are designed to provide strong threads in stainless steel sheets as thin as .040" / 1 mm. Type FHP studs have high corrosion resistance. Both types are designed for use in stainless steel sheets with a hardness of 92 or less on the Rockwell "B" scale. (See page FH-9)

**TPS (flush-head) Pilot Pins** satisfy a wide range of positioning, pivot, and alignment applications. The chamfered end makes mating hole location easy. (See page FH-10)

**HFE (high-strength) Studs** are designed with an enlarged head diameter to provide high-strength in sheets as thin as .040" / 1 mm. (See page FH-11)

**Dog Point and Anti Cross-Thread Options**  
(See page FH-12)



Flush-head Studs



Thin Sheet Studs



High-strength Studs



Low-displacement Head Studs



Flush-head Pins

## Part Number Designation

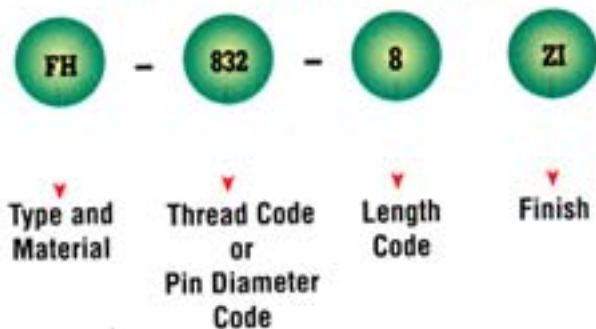

## PEM® Self-clinching Stud Selector Guide

PEM Stud Type	Page No.	Application Requires:									
		Flush-head	High-strength	Sheet thickness as thin as .020" / 0.51mm	High electrical conductivity	Mounting into stainless steel sheets	Compatibility with aluminum anodizing	Limited corrosion resistance	High corrosion resistance	Reduced centerline-to-edge distance	Unthreaded pin
FH	4	•									(1)
FHA	4	•					•		•		(1)
FHL	8	•								•	
FHLS	8	•							•	•	
FHS	4	•							•		(1)
FH4	9	•				•		•			
FHP	9	•				•			•		
HFH	7		•								
HFHB	7				•						
HFHS	7		•						•		
TFH	6			•							
TFHS	6			•					•		
TPS	10	•							•		•
HFE	11		•								

Standard product features shown above. Studs can also be custom designed to meet your exact application requirements  
 (1) Also available unthreaded on special order. See page FH-5.

To be sure that you are getting genuine PEM® brand self-clinching studs, look for the "dimple" trademark. (Reg. Pat. & T.M. Off. of the U.S. and other countries.)

The Trademark for Quality



# TYPE FH/FHS/FHA

- Flush-head for sheet thickness of .040" / 1 mm and greater.

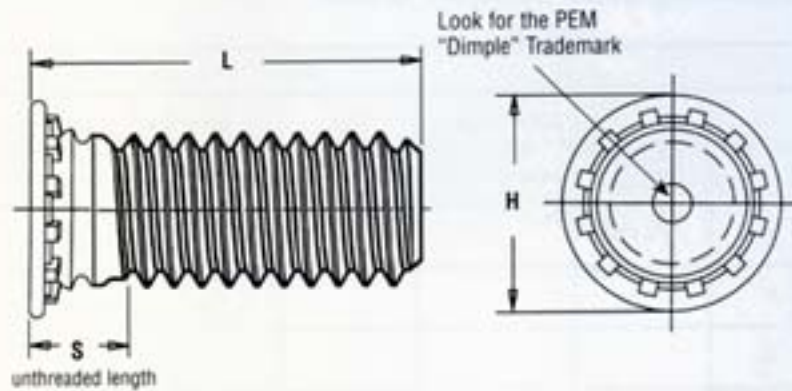

All dimensions are in inches.

UNIFIED	Thread Size	Type			Thread Code	Length Code "L" ±.015 (Length Code in 16ths of an inch)										Min. Sheet Thickness (1)	Hole Size in Sheet +.003 -.000	Max. Hole in Attach. Parts	H ± .015	S Max.	Min. Dist. Hole C/L to Edge
		Fastener Material				.250	.312	.375	.500	.625	.750	.875	1.00	1.25	1.50						
		Steel	Stainless Steel	Aluminum																	
	086-56 (#2-56)	FH	FHS	NA	256	4	5	6	8	10	12 <sup>NS</sup>	NA	NA	NA	NA	040	085	105	144	075	.187
	112-40 (#4-40)	FH	FHS	FHA	440	4	5	6	8	10	12	14 <sup>NS</sup>	16 <sup>NS</sup>	NA	NA	040	111	135	176	085	.219
	138-32 (#6-32)	FH	FHS	FHA	632	4	5	6	8	10	12	14	16	20	24 <sup>NS</sup>	040	137	160	206	090	.250
	164-32 (#8-32)	FH	FHS	FHA	832	4	5	6	8	10	12	14	16	20	24 <sup>NS</sup>	040	163	185	237	090	.281
	190-24 (#10-24)	FH	FHS	FHA <sup>NS</sup>	024	NA	5 <sup>NS</sup>	6	8	10	12	14	16	20	24 <sup>NS</sup>	040	189	210	256	100	.281
	190-32 (#10-32)	FH	FHS	FHA	032	NA	5 <sup>NS</sup>	6	8	10	12	14	16	20	24	040	189	210	256	100	.281
	250-20 (1/4-20)	FH	FHS	FHA	0420	NA	NA	6 <sup>NS</sup>	8	10	12	14	16	20	24	062	249	270	337	135	.312
	313-18 (5/16-18)	FH	FHS	NA	0518	NA	NA	NA	8 <sup>NS</sup>	10	12	14	16	20	24	093	311	333	376	160	.375

All dimensions are in millimeters.

METRIC	Thread Size x Pitch	Type			Thread Code	Length Code "L" ±0.4 (Length Code in millimeters)										Min. Sheet Thickness (1)	Hole Size in Sheet +0.08	Max. Hole in Attach. Parts	H ± 0.4	S Max.	Min. Dist. Hole C/L to Edge
		Fastener Material				6 <sup>NS</sup>	8	10	12	15	18	20 <sup>NS</sup>	25 <sup>NS</sup>	NA	NA						
		Steel	Stainless Steel	Aluminum																	
	M2.5x0.45	FH	FHS	FHA	M2.5	6 <sup>NS</sup>	8 <sup>NS</sup>	10 <sup>NS</sup>	12 <sup>NS</sup>	15 <sup>NS</sup>	18 <sup>NS</sup>	NA	NA	NA	NA	1	2.5	3.1	4.1	1.95	5.4
	M3x0.5	FH	FHS	FHA	M3	6 <sup>NS</sup>	8	10	12	15	18	20 <sup>NS</sup>	25 <sup>NS</sup>	NA	NA	1	3	3.6	4.6	2.1	5.6
	M3.5x0.6	FH	FHS	FHA	M3.5 <sup>NS</sup>	6	8	10	12	15	18	20	25	30	NA	1	3.5	4.1	5.3	2.25	6.4
	M4x0.7	FH	FHS	FHA	M4	6 <sup>NS</sup>	8	10	12	15	18	20	25	30 <sup>NS</sup>	35 <sup>NS</sup>	1	4	4.6	5.9	2.4	7.2
	M5x0.8	FH	FHS	FHA	M5	NA	8 <sup>NS</sup>	10	12	15	18	20	25	30 <sup>NS</sup>	35 <sup>NS</sup>	1	5	5.6	6.5	2.7	7.2
	M6x1	FH	FHS	FHA <sup>NS</sup>	M6	NA	NA	10	12	15	18	20	25	30	35	1.6	6	6.6	8.2	3	7.9
	M8x1.25	FH	FHS	NA	M8	NA	NA	NA	12 <sup>NS</sup>	15	18	20	25	30	35	2.4	8	8.6	9.6	3.7	9.6

NS Not Stocked, available on special order.

NA Not Available.

(1) See page FH-13 for installation tool requirements.

# TYPE FH/FHN/FHS/FHA UNTHREADED STUDS

- Flush-head for sheet thickness of .040" / 1 mm and greater.

**PEM® unthreaded studs are only available on special order. See page FH-10 for standard diameter pins.**

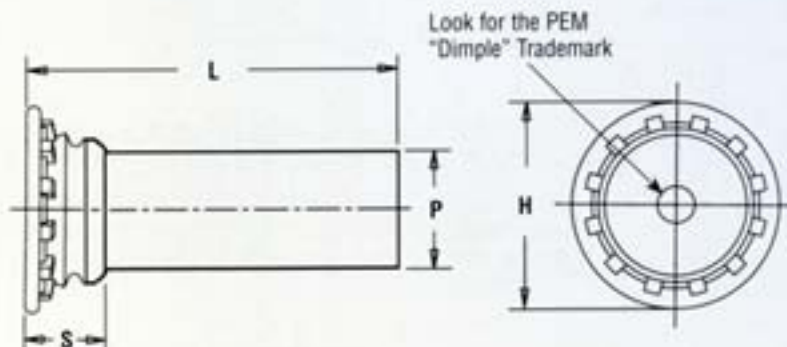

All dimensions are in inches.

(1) Nominal Pin Diameter P $\pm$ .002	Type				Pin Dia. Code	Length Code "L" $\pm$ .015 (Length Code in 16ths of an inch)										Min. Sheet Thick- ness	Hole Size in Sheet +.003 -.000	H $\pm$ .015	S Max. (3)	Min. Dist. Hole C/L to Edge
	Fastener Material					.250	.312	.375	.500	.625	.750	.875	1.00	1.25	1.50					
	Steel (2)	Stainless Steel	Alu- minum																	
.073	FH	FHN	FHS	FHA	073	4	5	6	8	10	NA	NA	NA	NA	NA	.040	.085	.15	.075	19
.084	FH	FHN	FHS	FHA	084	4	5	6	8	10	12	NA	NA	NA	NA	.040	.099	.16	.085	22
.094	FH	FHN	FHS	FHA	094	4	5	6	8	10	12	NA	NA	NA	NA	.040	.111	.18	.085	22
.103	FH	FHN	FHS	FHA	103	4	5	6	8	10	12	NA	NA	NA	NA	.040	.118	.18	.085	22
.106	FH	FHN	FHS	FHA	106	4	5	6	8	10	12	14	16	20	NA	.040	.125	.19	.090	22
.116	FH	FHN	FHS	FHA	116	4	5	6	8	10	12	14	16	20	NA	.040	.137	.21	.090	25
.120	FH	FHN	FHS	FHA	120	4	5	6	8	10	12	14	16	20	24	.040	.137	.21	.090	25
.137	FH	FHN	FHS	FHA	137	4	5	6	8	10	12	14	16	20	24	.040	.157	.23	.090	28
.141	FH	FHN	FHS	FHA	141	4	5	6	8	10	12	14	16	20	24	.040	.163	.24	.090	28
.160	FH	FHN	FHS	FHA	160	4	5	6	8	10	12	14	16	20	24	.040	.189	.26	.100	28
.167	FH	FHN	FHS	FHA	167	NA	5	6	8	10	12	14	16	20	24	.040	.189	.26	.100	28
.173	FH	FHN	FHS	FHA	173	NA	5	6	8	10	12	14	16	20	24	.040	.197	.26	.100	28
.207	FH	FHN	FHS	FHA	207	NA	5	6	8	10	12	14	16	20	24	.062	.236	.32	.135	.31
.215	FH	FHN	FHS	FHA	215	NA	NA	NA	8	10	12	14	16	20	24	.062	.250	.34	.135	.31
.223	FH	FHN	FHS	FHA	223	NA	NA	NA	8	10	12	14	16	20	24	.062	.250	.34	.135	.31
.273	FH	FHN	FHS	FHA	273	NA	NA	NA	8	10	12	14	16	20	24	.093	.312	.38	.160	.38
.281	FH	FHN	FHS	FHA	281	NA	NA	NA	8	10	12	14	16	20	24	.093	.312	.38	.160	.38

All dimensions are in millimeters.

METRIC	(1) Nominal Pin Diameter P $\pm$ 0.05	Type				Pin Dia. Code	Length Code "L" $\pm$ 0.4 (Length Code in millimeters)										Min. Sheet Thick- ness	Hole Size in Sheet +0.08	H $\pm$ 0.4	S Max. (3)	Min. Dist. Hole C/L to Edge
		Fastener Material					6	8	10	12	15	18	20	25	30	35					
		Steel (2)	Stainless Steel	Alu- minum																	
3	FH	FHN	FHS	FHA	3 mm	6	8	10	12	15	18	20	25	30	NA	1	3.5	5.3	2.3	6.4	
4	FH	FHN	FHS	FHA	4 mm	NA	8	10	12	15	18	20	25	30	35	1	4.1	6	2.3	7.1	
5	FH	FHN	FHS	FHA	5 mm	NA	8	10	12	15	18	20	25	30	35	1	5.5	7.5	2.55	7.6	

- (1) Other pin diameters can be specified.
  - (2) See chart on page FH-13 for details.
  - (3) Pin diameter may exceed max. in this region.
- NA Not Available.

# TYPE TFH/TFHS

- Non-flush for sheets as thin as .020" / 0.51 mm.

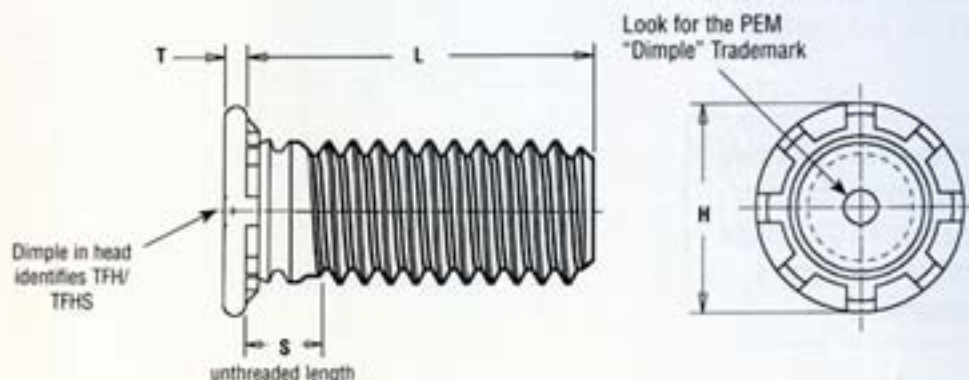
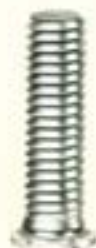

All dimensions are in inches.

UNIFIED	Thread Size	Type		Thread Code	Length Code "L" ±.015 (Length Code in 16ths of an inch)									Min. Sheet Thickness (1)	Hole Size in Sheet +.003 -.000	Max. Hole in Attach. Parts	H ±.015	S Max.	T Max.	Min. Dist. Hole C/L to Edge	
		Fastener Material Steel	Stainless Steel		.250	.312	.375	.500	.625	.750	.875	1.00	1.25								1.50
					TFH	TFHS	4 <sup>NS</sup>	5 <sup>NS</sup>	6 <sup>NS</sup>	8 <sup>NS</sup>	10 <sup>NS</sup>	12 <sup>NS</sup>	14 <sup>NS</sup>								16 <sup>NS</sup>
086-56 (#2-56)	TFH	TFHS	256	4 <sup>NS</sup>	5 <sup>NS</sup>	6 <sup>NS</sup>	8 <sup>NS</sup>	10 <sup>NS</sup>	12 <sup>NS</sup>	14 <sup>NS</sup>	16 <sup>NS</sup>	20 <sup>NS</sup>	24 <sup>NS</sup>	020	085	105	141	070	025	187	
112-40 (#4-40)	TFH	TFHS	440	4	5	6	8	10	12	14 <sup>NS</sup>	16 <sup>NS</sup>	20 <sup>NS</sup>	24 <sup>NS</sup>	020	111	135	176	070	025	219	
138-32 (#6-32)	TFH	TFHS	632	4	5	6	8	10	12	14 <sup>NS</sup>	16 <sup>NS</sup>	20 <sup>NS</sup>	24 <sup>NS</sup>	020	137	160	203	070	025	250	
164-32 (#8-32)	TFH	TFHS	832	4	5	6	8	10	12	14 <sup>NS</sup>	16 <sup>NS</sup>	20 <sup>NS</sup>	24 <sup>NS</sup>	020	163	185	234	070	025	281	
190-24 (#10-24)	TFH	TFHS	024 <sup>NS</sup>	NA	5	6	8	10	12	14	16	20	24	020	189	210	250	090	025	281	
190-32 (#10-32)	TFH	TFHS	032	NA	5 <sup>NS</sup>	6 <sup>NS</sup>	8	10	12	14	16 <sup>NS</sup>	20 <sup>NS</sup>	24 <sup>NS</sup>	020	189	210	250	090	025	281	

All dimensions are in millimeters.

METRIC	Thread Size x Pitch	Type		Thread Code	Length Code "L" ±0.4 (Length Code in millimeters)									Min. Sheet Thickness (1)	Hole Size in Sheet +0.08	Max. Hole in Attach. Parts	H ±0.4	S Max.	T Max.	Min. Dist. Hole C/L to Edge	
		Fastener Material Steel	Stainless Steel		6	8	10	12	15	18	20 <sup>NS</sup>	25 <sup>NS</sup>	30 <sup>NS</sup>								35 <sup>NS</sup>
					TFH	TFHS	M3	NA	8 <sup>NS</sup>	10	12	15	18								20 <sup>NS</sup>
M3x0.5	TFH	TFHS	M3	6	8	10	12	15	18	20 <sup>NS</sup>	25 <sup>NS</sup>	NA	NA	0.51	3	3.6	4.5	1.8	0.64	5.6	
M4x0.7	TFH	TFHS	M4	NA	8 <sup>NS</sup>	10	12	15	18	20 <sup>NS</sup>	25 <sup>NS</sup>	30 <sup>NS</sup>	35 <sup>NS</sup>	0.51	4	4.6	5.8	1.8	0.64	7.2	
M5x0.8	TFH	TFHS	M5	NA	8 <sup>NS</sup>	10	12	15	18	20 <sup>NS</sup>	25 <sup>NS</sup>	30 <sup>NS</sup>	35 <sup>NS</sup>	0.51	5	5.6	6.4	2.3	0.64	7.2	

NS Not Stocked, available on special order.

NA Not Available.

(1) See page FH-13 for installation tool requirements.

# TYPE HFH/HFHS/HFHB

- For high-strength applications in sheets as thin as .050" / 1.3 mm.
- Type HFHB for superior electrical/mechanical attachment in copper.

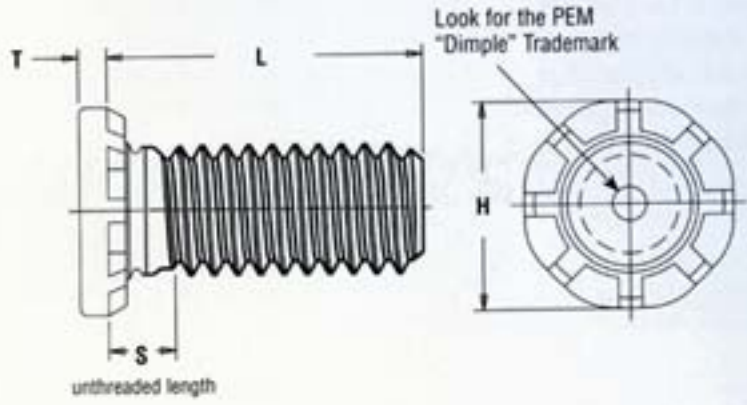

All dimensions are in inches.

UNIPIED	Thread Size	Type			Thread Code	Length Code "L" ±.015 (Length Code in 16ths of an inch)						Min. Sheet Thickness	Hole Size in Sheet +.005 -.000	Max. Hole in Attach. Parts	H ±.01	S Max.	T Max.	Min. Dist. Hole C/L to Edge
		Fastener Material																
		Steel	Stainless Steel	Phosphor Bronze (1)														
#10-32	HFH	HFHS	HFHB	032	.500	.750	1.00	1.25	1.50	1.75	2.00	050	190	250	300	105	040	415
(#10-32)	HFH	HFHS	HFHB	0420	.500	.750	1.00	1.25	1.50	1.75	2.00	060	250	312	380	125	050	460
313-18	HFH	HFHS	HFHB	0518	.500	.750	1.00	1.25	1.50	1.75	2.00	075	312	375	480	140	070	500
(5/16-18)	HFH	HFHS	HFHB	0616	NA	.750	1.00	1.25	1.50	1.75	2.00	090	375	437	580	155	085	530
375-16	HFH	HFHS	HFHB															
(3/8-16)	HFH	HFHS	HFHB															

Tensile strength HFH - 120 ksi / HFHS - 75 ksi / HFHB - 60 ksi

All dimensions are in millimeters.

METRIC	Thread Size x Pitch	Type			Thread Code	Length code "L" ±0.4 (Length Code in millimeters)						Min. Sheet Thickness	Hole Size in Sheet +0.13	Max. Hole in Attach. Parts	H ±0.25	S Max.	T Max.	Min. Dist. Hole C/L to Edge
		Fastener Material																
		Steel	Stainless Steel	Phosphor Bronze(1)														
M5x0.8	HFH	HFHS	HFHB	M5	15 <sup>NS</sup>	20	25 <sup>NS</sup>	30	35 <sup>NS</sup>	40 <sup>NS</sup>	50 <sup>NS</sup>	1.3	5	6.5	7.8	2.7	1.14	10.7
M6x1	HFH	HFHS	HFHB	M6	15*	20	25 <sup>NS</sup>	30	35 <sup>NS</sup>	40 <sup>NS</sup>	50 <sup>NS</sup>	1.5	6	7.5	9.4	2.8	1.27	11.5
M8x1.25	HFH	HFHS	HFHB	M8	15 <sup>NS</sup>	20	25 <sup>NS</sup>	30	35 <sup>NS</sup>	40 <sup>NS</sup>	50 <sup>NS</sup>	2	8	9.5	12.5	3.5	1.78	12.7
M10x1.5	HFH	HFHS	HFHB <sup>NS</sup>	M10	15 <sup>NS</sup>	20	25 <sup>NS</sup>	30	35 <sup>NS</sup>	40 <sup>NS</sup>	50 <sup>NS</sup>	2.3	10	11.5	15.7	4.1	2.29	13.7

Tensile strength HFH - 900 MPa / HFHS - 515 MPa / HFHB - 415 MPa

NS Not Stocked, available on special order.

NA Not Available.

(1) The electrical resistance (tested at 10 amps DC) between phosphor bronze studs and copper busbars is below 104µ ohms and 62µ ohms for the #10-32 / M5 and 3/8-16 / M10 thread sizes respectively, after repeated thermal and mechanical cycling. Consult our Marketing department for complete electrical resistance test data for type HFHB studs installed in copper.

\* Type HFHB-M6-15 is only available on special order

# TYPE FHL/FHLS™

- Installs closer to the edge of a sheet than standard studs with out causing that edge to bulge.
- Flush-head for sheet thickness .040" / 1 mm and greater.

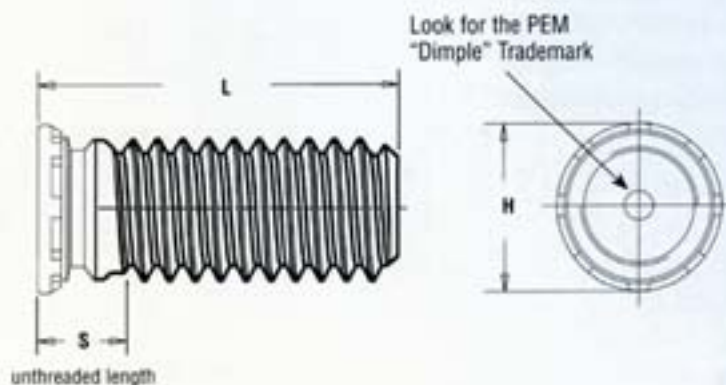

All dimensions are in inches.

	Thread Size	Type		Thread Code	Length Code "L" ±.015 (Length Code in 16ths of an inch)									Min. Sheet Thickness (1)	Hole Size in Sheet +.003 - .008	Max. Hole in Attach. Parts	H ±.015	S Max.	Min. Dist. Hole C/L to Edge	
		Fastener Material			.250	.312	.375	.500	.625	.750	.875	1.00	1.25							1.50
		Steel	Stainless Steel																	
UNIFIED	086-56 (#2-56)	FHL	FHLS	256	4	5	6	8	10	12	NA	NA	NA	NA	040	085	100	112	080	098
	112-40 (#4-40)	FHL	FHLS	440	4	5	6	8	10	12	14	16	NA	NA	040	111	125	138	085	124
	138-32 (#6-32)	FHL	FHLS	632	4	5	6	8	10	12	14	16	20	24	040	137	150	164	090	150
	164-32 (#8-32)	FHL	FHLS	832	4	5	6	8	10	12	14	16	20	24	040	163	180	190	090	176
	190-32 (#10-32)	FHL	FHLS	032	NA	5	6	8	10	12	14	16	20	24	040	189	205	225	100	210

All dimensions are in millimeters.

	Thread Size x Pitch	Type		Thread Code	Length Code "L" ±0.4 (Length Code in millimeters)									Min. Sheet Thickness (1)	Hole Size in Sheet +0.08	Max. Hole in Attach. Parts	H ±0.4	S Max.	Min. Dist. Hole C/L to Edge	
		Fastener Material			6	8	10	12	15	18	NA	NA	NA							NA
		Steel	Stainless Steel																	
METRIC	M2.5x0.45	FHL	FHLS	M2.5	6	8	10	12	15	18	NA	NA	NA	NA	1	2.5	2.9	3.15	2.1	2.8
	M3x0.5	FHL	FHLS	M3	6	8	10	12	15	18	20	25	NA	NA	1	3	3.4	3.65	2.1	3.3
	M3.5x0.6	FHL	FHLS	M3.5	6	8	10	12	15	18	20	25	30	NA	1	3.5	3.9	4.15	2.3	3.8
	M4x0.7	FHL	FHLS	M4	6	8	10	12	15	18	20	25	30	35	1	4	4.4	4.65	2.4	4.3
	M5x0.8	FHL	FHLS	M5	NA	8	10	12	15	18	20	25	30	35	1	5	5.4	5.9	2.7	5.6

NA Not Available

(1) See page FH-15 for installation tool requirements.

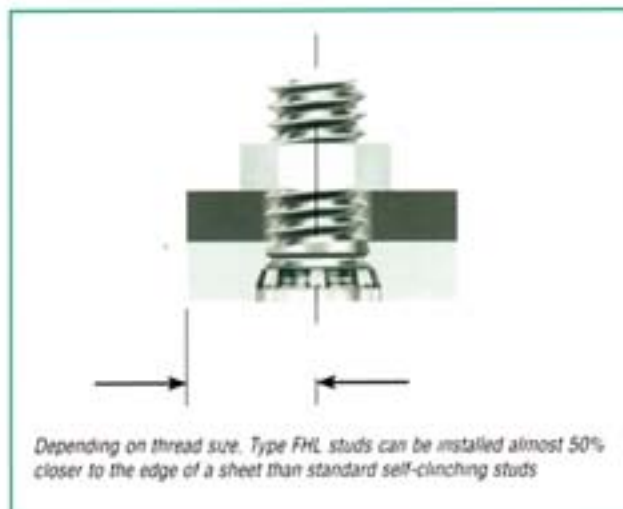

# TYPES FH4™ AND FHP™

- Permanent installation into stainless steel sheets as thin as .040" / 1 mm.
- For use in sheet hardness of 92 or less on the Rockwell "B" scale.
- Type FHP is high corrosion resistant and ideal for medical, foodservice, and marine applications.

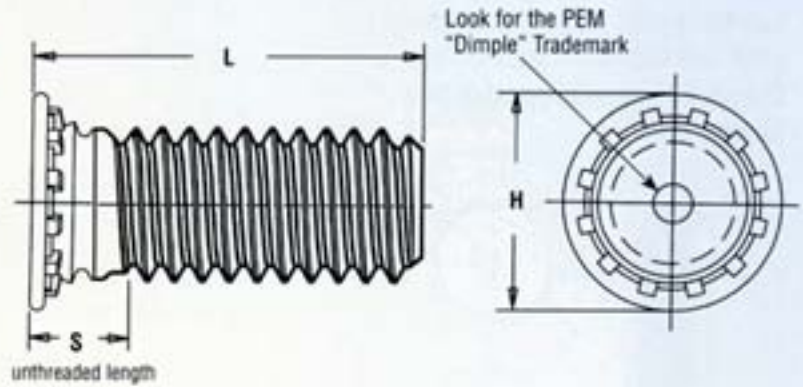

All dimensions are in inches.

UNIFIED	Thread Size	Type		Thread Code	Length Code "L" ±.015 (Length code in 16ths of an inch)										Sheet Thickness	Hole Size in Sheet +.003 -.000	Max. Hole in Attach. Parts	H ±.015	S Max.	Min. Dist. Hole C/L to Edge
					.250	.312	.375	.500	.625	.750	.875	1.00	1.25	1.50						
	112-40 (#4-40)	FH4	FHP	440	4	5	6	8	10	12 <sup>NS</sup>	14 <sup>NS</sup>	16 <sup>NS</sup>	NA	NA	040-095	111	135	176	.085	219
	138-32 (#6-32)	FH4	FHP	632	4	5	6	8	10	12	14	16	20	24 <sup>NS</sup>	040-095	137	160	206	.090	250
	164-32 (#8-32)	FH4	FHP	832	4	5	6	8	10	12	14	16	20	24 <sup>NS</sup>	040-095	163	185	237	.090	281
	190-32 (#10-32)	FH4	FHP	032	NA	5 <sup>NS</sup>	6	8	10	12	14	16	20	24	040-095	189	210	256	100	281
	250-20 (1/4-20)	FH4	NA	0420	NA	NA	6 <sup>NS</sup>	8	10	12	14	16	20	24	062-117	249	270	337	135	312

All dimensions are in millimeters.

METRIC	Thread Size x Pitch	Type		Thread Code	Length Code "L" ±0.4 (Length Code in millimeters)										Sheet Thickness	Hole Size in Sheet +0.08	Max. Hole in Attach. parts	H ±0.4	S Max.	Min. Dist. Hole C/L to Edge
					6 <sup>NS</sup>	8	10	12	15	18	20 <sup>NS</sup>	25 <sup>NS</sup>	NA	NA						
	M3 x 0.5	FH4	FHP	M3	6 <sup>NS</sup>	8	10	12	15	18	20 <sup>NS</sup>	25 <sup>NS</sup>	NA	NA	1 - 2.4	3	3.6	4.6	2.1	5.6
	M4 x 0.7	FH4	FHP	M4	6 <sup>NS</sup>	8	10	12	15	18	20	25	30 <sup>NS</sup>	35 <sup>NS</sup>	1 - 2.4	4	4.6	5.9	2.4	7.2
	M5 x 0.8	FH4	FHP	M5	NA	8 <sup>NS</sup>	10	12	15	18	20	25	30 <sup>NS</sup>	35 <sup>NS</sup>	1 - 2.4	5	5.6	6.5	2.7	7.2
	M6 x 1	FH4	NA	M6	NA	NA	10	12	15	18	20	25	30	35	1.6 - 3	6	6.6	8.2	3	7.9

NS Not Stocked, available on special order.

NA Not Available

# TYPE TPS™

- Flush-mounted, self-clinching pilot pins.
- Satisfies a wide range of positioning, pivot, and alignment applications.
- Chamfered end makes mating hole location easy.

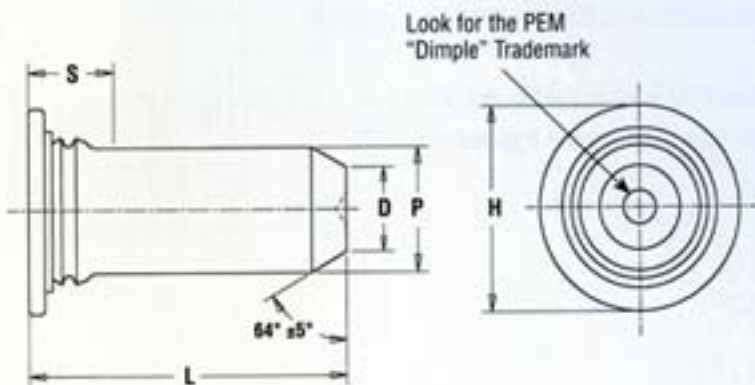

All dimensions are in inches.

UNIFIED	Pin Diameter P ± .002	Type	Pin Diameter Code	Length Code "L" ± .015 (Length Code in 16ths of an inch)					Min. Sheet Thickness	Hole Size in Sheet +.003 - .000	D ± .006	H ± .015	S Max. (1)	Min. Distance Hole C/L to Edge
				.375	.500	.625	.750	1.00						
	125	TPS	125	6	8	10	12	NA	.040	.144	.090	.205	.090	.250
	187	TPS	187	6	8	10	12	16	.040	.205	.132	.270	.090	.280
	250	TPS	250	NA	8	10	12	16	.040	.272	.177	.335	.090	.310

All dimensions are in millimeters.

METRIC	Pin Diameter P ± 0.05	Type	Pin Diameter Code	Length Code "L" ± 0.4 (Length Code in millimeters)					Min. Sheet Thickness	Hole Size in Sheet +0.08	D ± 0.15	H ± 0.4	S Max. (1)	Min. Distance Hole C/L to Edge
				8	10	12	16	NA						
	3	TPS	3mm	8	10	12	16	NA	1	3.5	2.05	5.2	2.29	6.4
	4	TPS	4mm	8	10	12	16	NA	1	4.5	2.82	6.12	2.29	7.1
	5	TPS	5mm	NA	10	12	16	20	1	5.5	3.53	7.19	2.29	7.6
	6	TPS	6mm	NA	NA	12	16	20	1	6.5	4.24	8.13	2.29	7.9

(1) Pin diameter may exceed max. in this region.  
NA Not Available.

# TYPE HFE™

- Enlarged head diameter provides high-strength in sheets as thin as .040" / 1 mm.

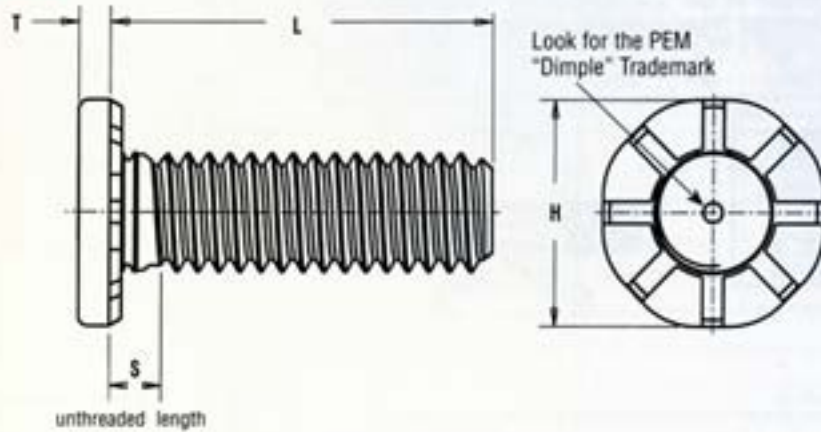

All dimensions are in inches.

UNIPIED	Thread Code	Type	Thread Code	Length Code "L" ±.015 (Length Code in 16ths of an inch)						Min. Sheet Thickness (1)	Hole Size in Sheet +.005 -.000	H ±.01	S Max.	T Max.	Max. Hole in Attached Parts	Min. Dist. Hole C/L To Edge	
				.500	.750	1.00	1.25	1.50	1.75								2.00
	190-32 (#10-32)	HFE	032	8 <sup>NS</sup>	12	16	20	24 <sup>NS</sup>	28 <sup>NS</sup>	32 <sup>NS</sup>	040	190	357	102	048	280	360
	250-20 (1/4-20)	HFE	0420	8 <sup>NS</sup>	12	16	20	24 <sup>NS</sup>	28 <sup>NS</sup>	32 <sup>NS</sup>	040	250	462	118	060	340	470
	313-18 (5/16-18)	HFE	0518	8 <sup>NS</sup>	12	16	20	24	28 <sup>NS</sup>	32 <sup>NS</sup>	060	312	586	133	083	402	560

Thread strength 120 ksi

All dimensions are in millimeters.

METRIC	Thread Code x Pitch	Type	Thread Code	Length Code "L" ±0.4 (Length Code in Millimeters)						Min. Sheet Thickness (1)	Hole Size in Sheet +0.13	H ±0.25	S Max.	T Max.	Max. Hole in Attached Parts	Min. Dist. Hole C/L To Edge	
				15 <sup>NS</sup>	20	25 <sup>NS</sup>	30	35 <sup>NS</sup>	40 <sup>NS</sup>								50 <sup>NS</sup>
	M5 x 0.8	HFE	M5	15 <sup>NS</sup>	20	25 <sup>NS</sup>	30	35 <sup>NS</sup>	40 <sup>NS</sup>	50 <sup>NS</sup>	1	5	9.6	2.6	1.35	7.3	10
	M6 x 1	HFE	M6	15 <sup>NS</sup>	20	25 <sup>NS</sup>	30	35 <sup>NS</sup>	40 <sup>NS</sup>	50 <sup>NS</sup>	1	6	11.35	2.8	1.52	8.3	11.5
	M8 x 1.25	HFE	M8	15 <sup>NS</sup>	20	25 <sup>NS</sup>	30	35 <sup>NS</sup>	40 <sup>NS</sup>	50 <sup>NS</sup>	1.5	8	15.3	3.3	2.13	10.3	14.5

Thread strength 900 MPa

NS Not Stocked, available on special order.

(1) See page FH-17 for installation tool requirements.

# Dog Point And Anti Cross-Threading Options For Studs

PEM® AUTOSPEC® dog point lead-in option for studs allows quick location of the mating fastener during assembly and protects the first thread of the stud during nut engagement. This feature is available on Types FH, HFH, and HFE studs.



Dog Point Stud

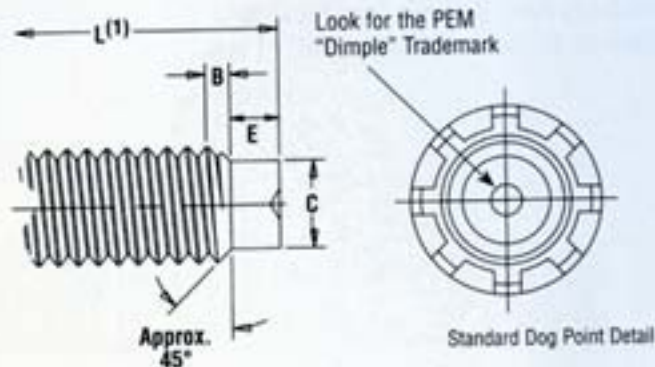

All dimensions are in inches.

UNIFIED	Thread Size	C ±.005 (2)	E ±.010	B Nom. Transitional Length to Full Thread
	.138-32 (#6-32)	.086	.050	.098
	.164-32 (#8-32)	.111	.055	.099
	.190-24 (#10-24)	.124	.065	.127
	.190-32 (#10-32)	.138	.065	.098
	.250-20 (1/4-20)	.173	.085	.149
	.250-28 (1/4-28)	.192	.085	.110
	.313-18 (5/16-18)	.228	.105	.164
	.313-24 (5/16-24)	.246	.105	.127
	.375-16 (3/8-16)	.282	.125	.182
	.375-24 (3/8-24)	.309	.125	.126

All dimensions are in millimeters.

METRIC	Thread Size x Pitch	C ±0.13 (2)	E ±0.25	B Nom. Transitional Length to Full Thread
	M3.5 x 0.6	2.4	1.27	1.88
	M4 x 0.7	2.79	1.4	2.26
	M5 x 0.8	3.66	1.78	2.48
	M6 x 1	4.37	2.03	3.05
	M8 x 1.25	6.05	2.67	3.73
	M10 x 1.5	7.72	3.43	4.37

### Type Designation



FH Stud  
with dog  
point



Material  
(if applicable)

PennEngineering is a licensee of MATHread® Anti Cross-Threading Technology. This unique design allows the threads to self-align and drive easily with reduced effort. This helps speed assembly, reduce or eliminate failures, repairs, scrap, downtime, and warranty service associated with thread damage. This option is available on most types of PEM studs.



Anti Cross-Thread Feature

### Here's how it works:



#### Misaligned Axis

The anti cross-threading design offers users the benefit of self-aligning, anti cross-threading threads.



#### Threads Cam

As the threads come into contact, the patented anti cross-thread begins to cam over the female thread.

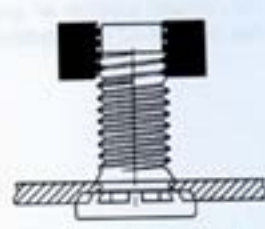

#### Threads Drive Normally

The anti cross-threads promote alignment of the two thread helixes. The fasteners drive easily with reduced effort.

(1) For "L" refer to type FH, HFE, or HFH lengths

(2) Maximum dog point diameter is .003" / 0.08 mm less than minimum minor diameter of 2B or 6H nut threads.

If required, studs are supplied with raw material and plating certifications as required by automotive industry standards.

MATHread is a registered trademark of MATHread inc

# MATERIAL & FINISH SPECIFICATIONS

Type	Threads (1)	Fastener Materials						Standard Finishes			Optional Finish (2)	For use in Sheet Hardness:						
	External, ANSI B1.1, 2A ANS/ASME B1.13M 6g	Heat-Treated Carbon Steel	Carbon Steel	300 Series Stainless Steel	2024-T4 Aluminum (Plain Finish)	CDA #510 Phosphor Bronze (3)	Precipitation Hardening Grade Stainless Steel	400 Series Stainless Steel	No Finish (4) (5)	Zinc Per ASTM B 633 SC1 (5µm), Type III, Colorless	Passivated and/or Tested Per ASTM A380	Zinc Per ASTM B 633 SC1 (5µm) Type II, Yellow	50 or less on the Rockwell "B" Scale	55 or less on the Rockwell "B" Scale	70 or less on the Rockwell "B" Scale	80 or less on the Rockwell "B" Scale	85 or less on the Rockwell "B" Scale	92 or less on the Rockwell "B" Scale
FH	*	*							*		*					*		
FHS	*			*						*					*			
FHA	*				*			*										
FHN	*		*						*		*	*						
FH4	*							*		*								*
FHP	*						*			*								*
FHL	*	*							*							*		
FHLS	*			*						*				*				
TFH	*	*							*		*				*			
TFHS	*			*						*				*				
HFH	*	*							*		*					*		
HFHB	*					*		*					*					
HFHS	*			*						*				*				
TPS				*						*				*				
HFE	*	*							*		*						*	
Part Number Codes for Finishes								X	ZI	None	ZC							

- (1) For plated studs, Class 2A/6g, the maximum major and pitch diameter, after plating, may equal basic sizes and be gauged to Class 3A/4h. Per ANSI B1.1, Section 8, Table 3A and ANSI B1.13M, Section 8, paragraph 8.2
- (2) Special order with additional charge.
- (3) Material properties – yield strength: 50,000 psi (345 MPa), tensile strength: 63,000 psi (434 MPa)
- (4) Part numbers for aluminum studs have no plating suffix.
- (5) "X" suffix studs may have pitch diameters and major diameters below 2A "Basic", per ANSI B1.1, Section 7, and B1.13M, Section 8 to allow for minimum of 0.0002" of plating.

## INSTALLATION

### For Types FH, FHS, FHA, FHL, FHLS, TFH, TFHS, HFH, HFHB, HFHS and HFE studs

PEM brand self-clinching studs are installed by placing them in punched or drilled holes in the sheet material and squeezing them into place with any standard press.

All that is required is a flat or recessed punch and a plain anvil having a hole to clear the thread diameter so that force is applied between the top of the stud head and underside of the sheet material. The squeezing action forces the ribs of the stud into the sheet, displacing sheet material, causing it to fill the annular groove under the head of the stud.

The following information provides specifics with regard to stud installation.

All dimensions are in inches.

	Thread Code	Anvil Dimensions	
		A	C
UNIFIED	256	110-114	087-090
	440	136-140	113-116
	632	162-166	139-142
	832	188-192	165-168
	024 & 032	216-220	191-194
	0420	295-300	250-253
	0518	334-338	3125-3155
	0616	-	375-378

All dimensions are in millimeters.

	Thread Code	Anvil Dimensions	
		A + 0.1	C + 0.08
METRIC	M2.5	3.1	2.53
	M3	3.6	3.03
	M3.5	4.1	3.53
	M4	4.6	4.03
	M5	5.6	5.03
	M6	6.6	6.03
	M8	8.6	8.03
	M10	-	10.03

# INSTALLATION (Continued)

## Type FH/FHN/FHS/FHA (Flush) Threaded and Unthreaded Studs

The illustrations below indicate suggested tooling for applying installation forces. Note that for sheets .060" / 1.51 mm and thicker, the anvil requires only a straight thru hole to accommodate the stud. For sheets less than .060" / 1.51 mm, the hole requires a countersink with dimension A at the top to provide for metal flow around the shank of the stud.

Tooling for sheet thicknesses less than .060" / 1.51 mm with #2 thru #10 / M3 thru M5 thread sizes and less than .093" / 2.4 mm for 1/4" / M6 threads.

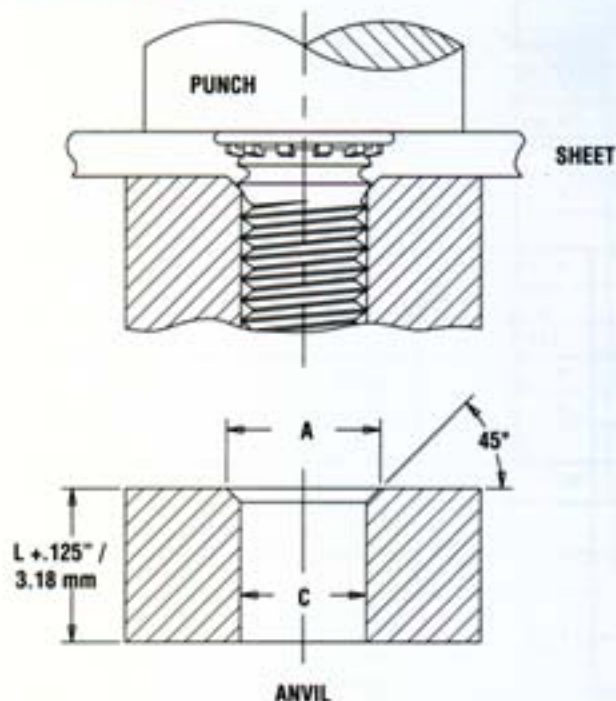

Tooling for sheet thicknesses .060" / 1.51 mm and greater with #2 thru #10 / M3 thru M5 thread sizes and .093" / 2.41 mm and greater for 1/4" and 5/16" / M6 and M8 threads.

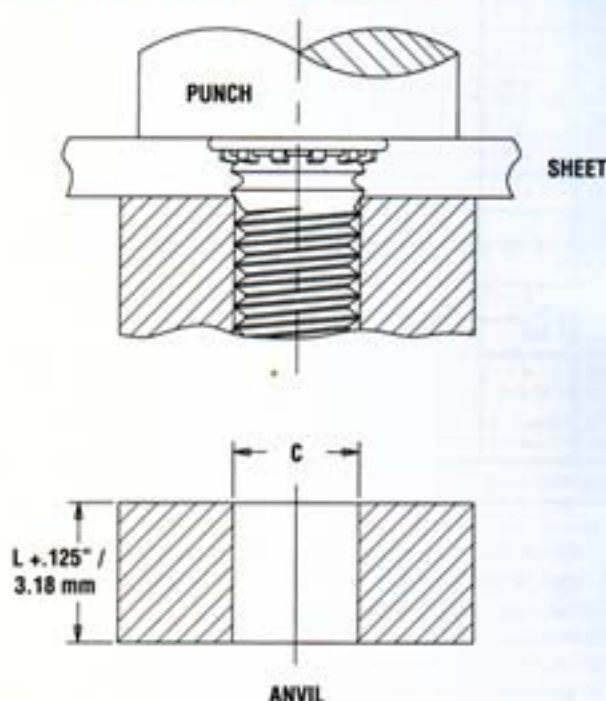

## Type TFH/TFHS (Non-Flush) Studs

The illustrations below indicate suggested tooling for type TFH studs. Note that for sheets .030" / 0.76 mm and thicker, the anvil requires only a straight thru hole to accommodate the stud. For sheets less than .030" / 0.76 mm down to .020" / 0.51 mm, the hole requires a countersink with dimension A at the top to provide for metal flow around the shank of the stud. The standard punch design below provides clearance for the stud head and reduces chances of over squeezing the head of the stud into the sheet metal. When installed, the stud head is not flush but will protrude approximately .025" / 0.64 mm.

Tooling for sheet thicknesses less than .030" / 0.76 mm down to .020" / 0.51 mm.

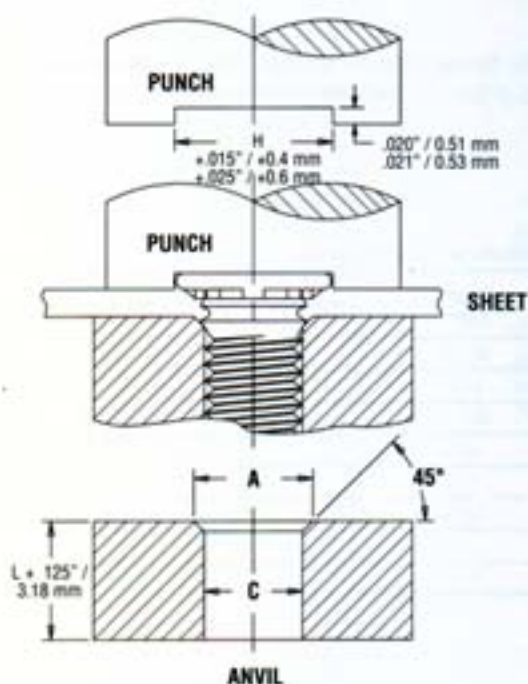

Tooling for sheet thicknesses .030" / 0.76 mm and greater.

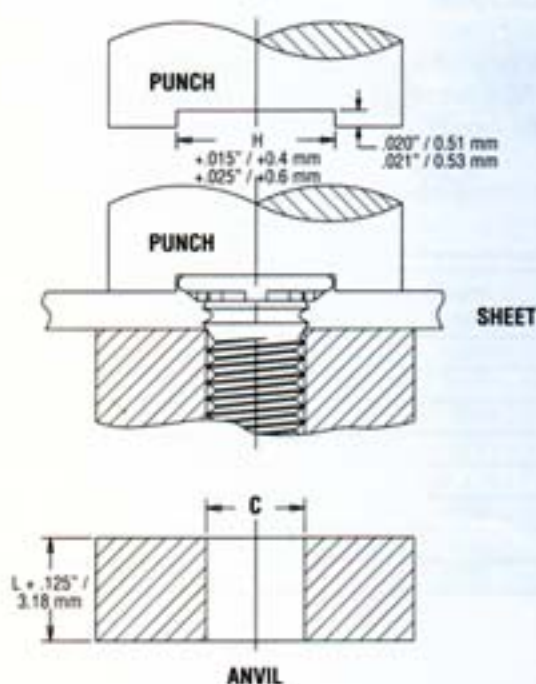

# INSTALLATION (Continued)

## Type HFH/HFHB/HFHS Studs

Apply squeezing force on the punch sufficient only to embed the ribs on the head of the stud into the sheet.

The illustration below indicates suggested tooling for Type HFH self-clinching studs. The standard punch design provides clearance for the stud head and reduces chances of over squeezing.

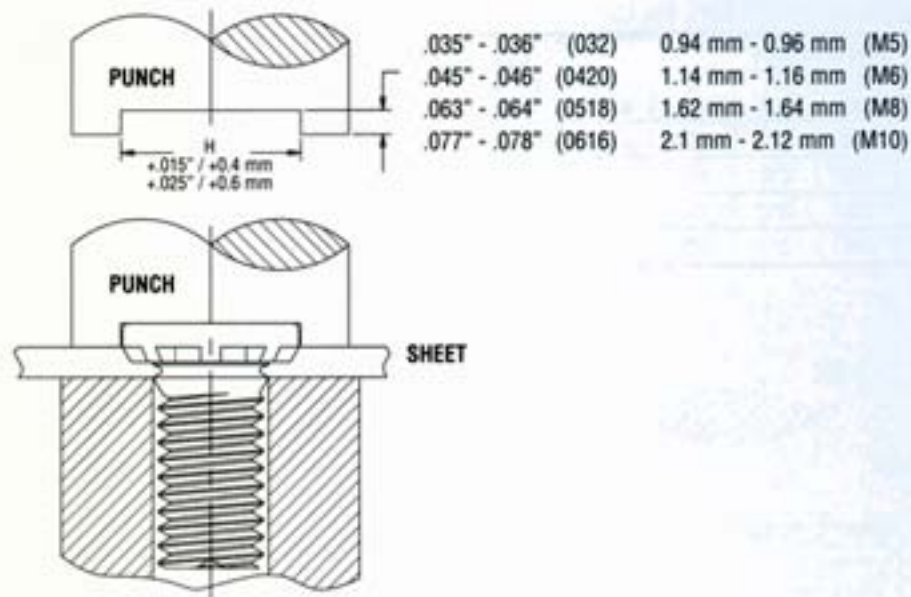

## Type FHL/FHLS Studs

The illustrations below indicate suggested tooling for applying installation forces. Note that for sheets .060" / 1.51 mm and thicker, the anvil requires only a straight thru hole to accommodate the stud. For sheets less than .060" / 1.51 mm, the hole requires a countersink with dimension A at the top to provide for metal flow around the shank of the stud.

Tooling for sheet thicknesses less than .060" / 1.51 mm.

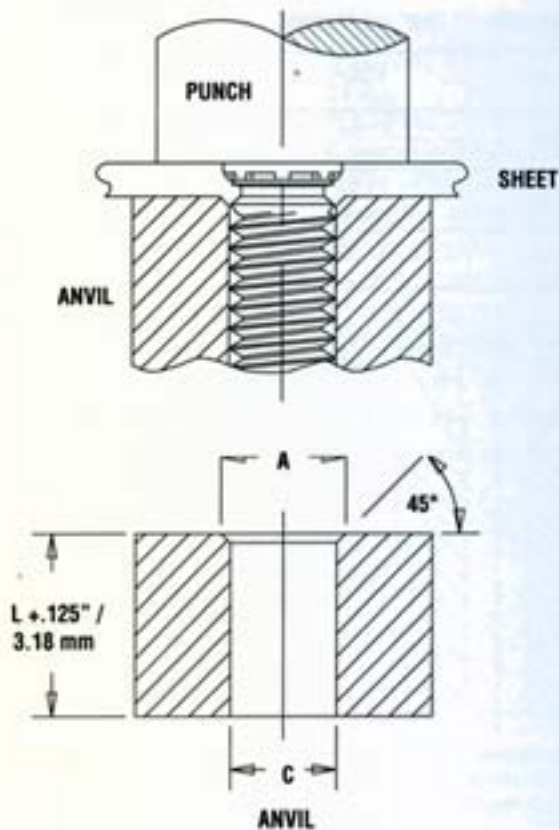

Tooling for sheet thicknesses .060" / 1.51 mm and greater.

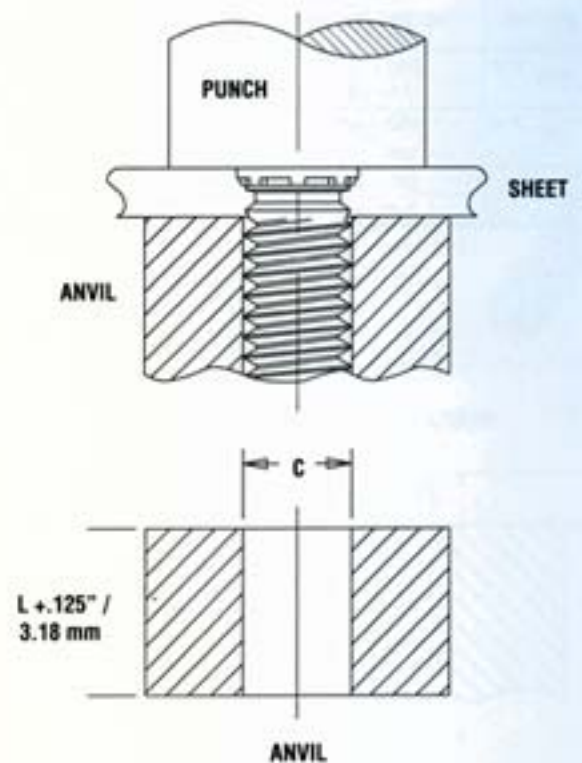

# INSTALLATION (Continued)

## Type FH4 and FHP Self-Clinching Studs for Stainless Steel

For Type FH4 studs, a special anvil with a raised ring is required to create a proper installation. The raised ring acts as a second displacer of the stainless sheet material, thereby ensuring that the annular groove is filled. We do not recommend the use of FH4 studs in sheet thicknesses greater than .095" / 2.41 mm.

The special anvils are available from PEM stock or can be machined from suitable tool steel. A hardness of Rc55 minimum is required to provide long anvil life. We recommend measuring the "P" dimension every 5000 installations to ensure that the anvil remains within specification.

All dimensions are in inches.

UNIFIED	Thread Code	Anvil Dimensions					Anvil Part No.	
		A +.003 - .000	B ±.002	C ±.002	P ±.001	R <sub>1</sub> Max.		R <sub>2</sub> Max.
	440	.113	.144	.174	.010	.003	.005	8001645
	632	.140	.170	.200	.010	.003	.005	8001644
	832	.166	.202	.236	.010	.003	.005	8001643
	032	.191	.235	.275	.010	.003	.005	8001642

All dimensions are in millimeters.

METRIC	Thread Code	Anvil Dimensions					Anvil Part No.	
		A +0.08	B ±0.05	C ±0.05	P ±0.025	R <sub>1</sub> Max.		R <sub>2</sub> Max.
	M3	3.05	3.81	4.57	0.25	0.08	0.13	8001678
	M4	4.04	4.95	5.82	0.25	0.08	0.13	8001677
	M5	5.08	6.15	7.16	0.25	0.08	0.13	8001676

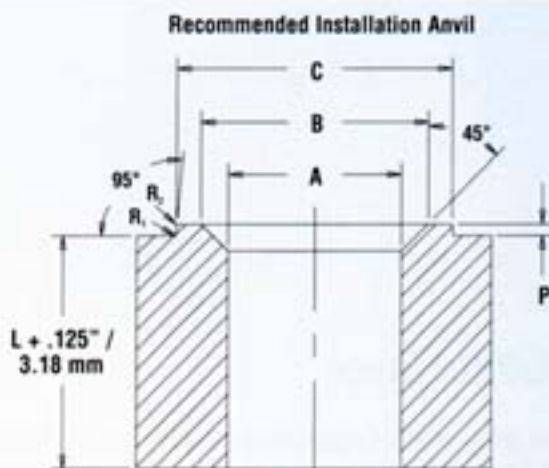
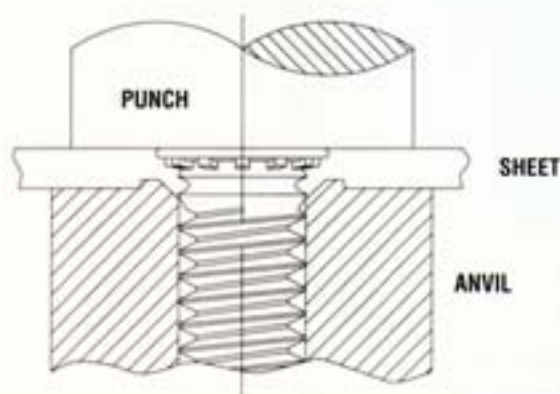

## Type TPS Flush-Mounted, Self-Clinching Pilot Pins

All dimensions are in inches.

UNIFIED	Pin Dia. Code	Test Sheet Thickness	Anvil Dimensions	
			A ±.002	C ±.002
	125	.040 - .060	.160	130
		Over .060	(1)	
	187	.040 - .065	.220	192
		Over .065	(1)	
	250	.040 - .075	.285	255
		Over .075	(1)	

All dimensions are in millimeters.

METRIC	Pin Dia. Code	Test Sheet Thickness	Anvil Dimensions	
			A ±0.05	C ±0.05
	3mm	1 - 1.7	3.88	3.11
		Over 1.7	(1)	
	4mm	1 - 1.7	4.88	4.11
		Over 1.7	(1)	
	5mm	1 - 1.8	5.89	5.13
		Over 1.8	(1)	
	6mm	1 - 1.9	6.89	6.12
		Over 1.9	(1)	

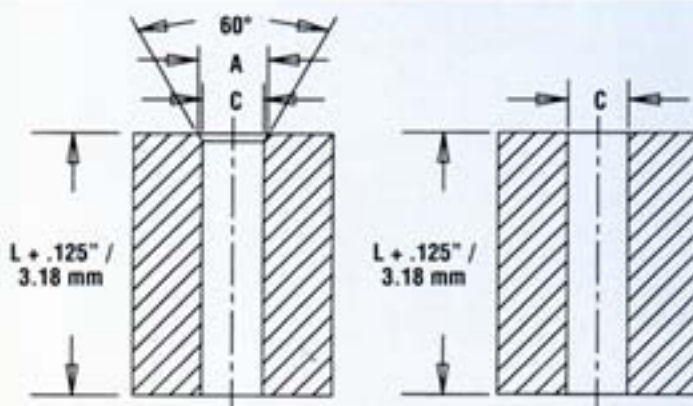
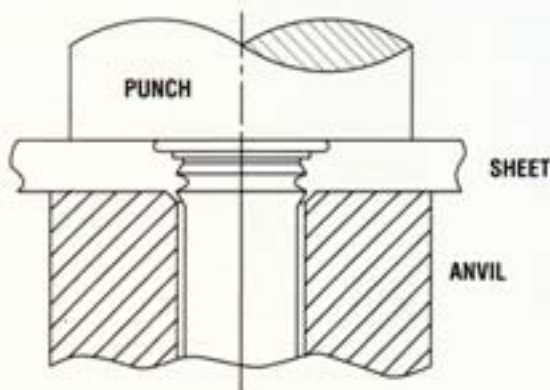

Recommended tooling when a chamfered anvil is required.

Recommended tooling when a chamfered anvil is not required.

(1) Chamfered anvil not required.

# INSTALLATION (Continued)

## Type HFE Studs

The illustrations below indicate suggested tooling for applying installation forces. Note that for sheets .060" / 1.51 mm and thicker, the anvil requires only a straight thru hole to accommodate the stud. For sheets less than .060" / 1.51 mm to less than .075" / 1.9 mm, the hole requires a countersink with dimension A at the top to provide for metal flow around the shank of the stud.

Tooling for sheet thicknesses less than .060" / 1.51 mm with #10 / M5 and 1/4" / M6 thread sizes and less than .075" / 1.9 mm with 5/16" / M8 threads.

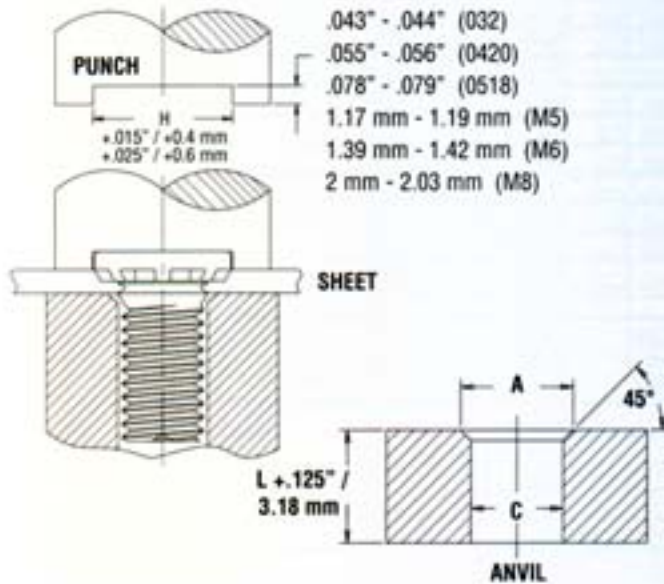

Tooling for sheet thicknesses .060" / 1.51 mm and greater with #10 / M5 and 1/4" / M6 thread sizes and .075" / 1.9 mm and greater with 5/16" / M8 threads.

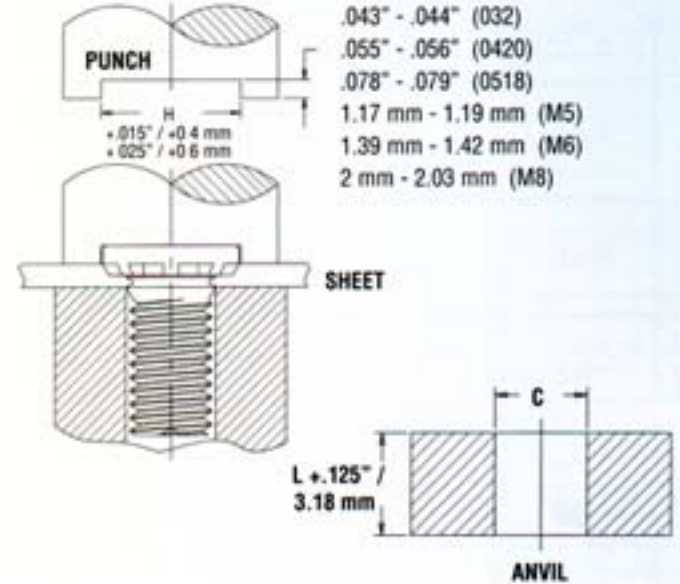

## Other Considerations

### Installation Equipment

For best results we recommend using a PEMSERTER® press for either manual or automatic installation of PEM® FH, FHS, FHA, FHL, FHLS, FH4, TFH, TFHS, HFH, HFHB, HFHS and TPS fasteners. To further reduce costs, the PEMSERTER In-die system allows you install PEM brand studs during the stamping process. This eliminates secondary insertion operations and improves quality. For more information on our line of presses call 1-800-523-5321 (USA only).

### Thread Mask

PEM® Blu-Coat™ thread mask is available for applications where hardware is installed prior to painting. During assembly, the threads of the mating hardware will remove paint, electro deposited automotive under coatings, and weld spatter upon application of torque. PEM studs can be specially ordered with thread mask applied.



# PERFORMANCE DATA

The pushout, torque-out, and pull thru values reported here pertain only to the holding power of the stud to the sheet into which it is installed. These values in no way pertain to the axial strength of the threads, allowable tightening torque or design loading of an assembly. The values reported are anticipated **destructive averages** when all installation specifications and procedures are followed. When properly installed, PEM self-clinching studs should perform better than the values given here.

## Type FH and FHS Flush-Head Studs

UNIFIED	Thread Code	Max. Nut Tightening Torque (in. lbs.) <sup>(1)</sup>	Type	Test Sheet Thickness and Material	Sheet Hardness HRB	Installation (lbs.)	Pushout (lbs.)	Torque-out (in. lbs.)	Pull Thru (lbs.)
	256	2.3	FH	.062" Aluminum	29	2000	100	5	425
			FHS	.062" Aluminum	29	2000	100	4.5	300
			FH	.060" Steel	59	2500	180	5	425
			FHS	.060" Steel	59	2500	180	4.5	300
	440	5	FH	.064" Aluminum	29	3800	170	10	650
			FHS	.064" Aluminum	29	3200	170	8	500
			FH	.060" Steel	59	4300	275	10	650
			FHS	.060" Steel	59	4700	275	8	500
	632	9	FH	.064" Aluminum	29	3800	180	17	850
FHS			.064" Aluminum	29	3500	180	16	775	
FH			.060" Steel	59	4700	300	20	850	
FHS			.060" Steel	59	5000	300	16	775	
832	17	FH	.064" Aluminum	29	4800	220	28	1000	
		FHS	.064" Aluminum	29	4500	220	28	940	
		FH	.060" Steel	59	6800	375	40	1270	
		FHS	.060" Steel	59	5500	375	28	1130	
032	27	FH	.064" Aluminum	29	5500	270	30	1220	
		FHS	.064" Aluminum	29	5500	270	30	1220	
024	24	FH	.060" Steel	59	7500	450	60	1410	
		FHS	.060" Steel	59	6800	450	50	1410	
0420	58	FH	.093" Aluminum	28	6500	310	65	2300	
		FHS	.093" Aluminum	28	6500	310	65	2100	
		FH	.088" Steel	46	9500	575	100	2550	
		FHS	.088" Steel	46	10000	575	100	2550	
0518	120	FH	.093" Aluminum	28	6500	430	100	2260	
		FHS	.093" Aluminum	28	6700	430	100	2260	
		FH	.093" Steel	46	10000	650	175	3475	
		FHS	.093" Steel	46	11200	650	175	3120	

METRIC	Thread Code	Max. Nut Tightening Torque (N•m) <sup>(1)</sup>	Type	Test Sheet Thickness and Material	Sheet Hardness HRB	Installation (kN)	Pushout (N)	Torque-out (N•m)	Pull Thru (N)
	M2.5	0.41	FH	1.6 mm Aluminum	29	8.9	465	1.0	2600
			FHS	1.6 mm Aluminum	29	11.6	465	0.8	1820
			FH	1.5 mm Steel	59	11.1	740	1.0	2800
			FHS	1.5 mm Steel	59	13.8	740	0.8	1820
	M3	0.74	FH	1.6 mm Aluminum	29	12.9	600	1.7	3150
			FHS	1.6 mm Aluminum	29	12.9	600	1.3	2570
			FH	1.5 mm Steel	59	14.7	820	1.7	3840
			FHS	1.5 mm Steel	59	14.7	820	1.3	2440
	M3.5	1.15	FH	1.6 mm Aluminum	29	15.6	800	1.7	3780
FHS			1.6 mm Aluminum	29	15.6	800	1.7	3445	
FH			1.5 mm Steel	59	22.3	1335	2.8	3780	
FHS			1.5 mm Steel	59	22.3	1335	2.0	3445	
M4	1.7	FH	1.6 mm Aluminum	29	20	975	2.9	4448	
		FHS	1.6 mm Aluminum	29	22.3	975	2.9	4180	
		FH	1.5 mm Steel	59	28.9	1780	4.2	5650	
		FHS	1.5 mm Steel	59	26.7	1780	2.9	4775	
M5	3.5	FH	1.6 mm Aluminum	29	24.5	1070	3.5	5170	
		FHS	1.6 mm Aluminum	29	24.5	1070	3.5	4760	
		FH	1.5 mm Steel	59	33.4	2000	6.5	6270	
		FHS	1.5 mm Steel	59	32.5	2000	6.3	6000	
M6	5.9	FH	2.4 mm Aluminum	28	28.9	1660	7.3	10200	
		FHS	2.4 mm Aluminum	28	28.9	1660	7.3	9090	
		FH	2.2 mm Steel	46	44.5	2560	11.3	11300	
		FHS	2.2 mm Steel	46	44.5	2560	10.1	10600	
M8	14.2	FH	2.4 mm Aluminum	28	29.8	1910	11.3	10500	
		FHS	2.4 mm Aluminum	28	29.8	1910	11.3	9540	
		FH	2.4 mm Steel	46	44.5	2890	19.2	15450	
		FHS	2.4 mm Steel	46	49.8	2890	17.5	13630	

(1) Maximum recommended tightening torques for aluminum studs are 60 percent of these values.

# PERFORMANCE DATA (Continued)

## Type TFH and TFHS Non-Flush Studs

UNIFIED	Thread Code	Max. Nut Tightening Torque (in. lbs.)	Type	Test Sheet Thickness and Material	Sheet Hardness HRB	(1) Installation (lbs.)	Pushout (lbs.)	Torque-out (in. lbs.)
	440	5	TFH	.020" Aluminum	28	1300	45	7
			TFHS	.020" Aluminum	28	1200	45	7
			TFH	.023" Steel	52	2800	100	8
			TFHS	.025" Steel	52	1500	100	8
	632	9	TFH	.020" Aluminum	28	2100	50	8
			TFHS	.020" Aluminum	28	1500	50	8
			TFH	.023" Steel	52	2500	110	16
			TFHS	.025" Steel	52	2500	110	16
	832	17	TFH	.020" Aluminum	28	2100	60	10
TFHS			.020" Aluminum	28	2200	60	11	
TFH			.023" Steel	52	3100	120	26	
TFHS			.025" Steel	52	2700	120	26	
024	24	TFH	.020" Aluminum	28	2300	65	14	
		TFHS	.020" Aluminum	28	2500	65	14	
032	27	TFH	.023" Steel	52	3700	150	30	
		TFHS	.025" Steel	52	3000	130	28	

METRIC	Thread Code	Max. Nut Tightening Torque (N•m)	Type	Test Sheet Thickness and Material	Sheet Hardness HRB	(1) Installation (kN)	Pushout (N)	Torque-out (N•m)
	M3	0.74	TFH	0.5 mm Aluminum	28	5.8	195	0.6
			TFHS	0.5 mm Aluminum	28	5.3	195	0.6
			TFH	0.6 mm Steel	52	12.5	300	1
			TFHS	0.6 mm Steel	52	6.7	300	1
	M4	1.7	TFH	0.5 mm Aluminum	28	12.5	250	0.7
			TFHS	0.5 mm Aluminum	28	9.8	250	0.7
			TFH	0.6 mm Steel	52	17.8	500	2.5
			TFHS	0.6 mm Steel	52	13.4	500	2.5
	M5	3.5	TFH	0.5 mm Aluminum	28	15.6	270	1.3
TFHS			0.5 mm Aluminum	28	13.4	270	1.3	
TFH			0.6 mm Steel	52	26.7	670	3	
TFHS			0.6 mm Steel	52	17.8	670	3	

(1) Installation controlled by proper cavity depth in punch.

# PERFORMANCE DATA (Continued)

## Type HFH and HFHS High Strength Studs and Type HFHB Phosphor Bronze Studs

UNIFIED	Thread Code	Type	Max. Nut Tightening Torque (ft. lbs.)	Test Sheet Thickness and Material	Sheet Hardness HRB	(1) Installation (lbs.)	Pushout (lbs.)	Torque-out (ft. lbs.)	(2) Tensile Strength (lbs.)
	032	HFH	.060" Aluminum	3.25	.060" Aluminum	15	3000	180	4
HFH		.060" Steel	3.25	.060" Steel	65	6000	375	5	2400
HFHS		.050" Aluminum	3.25	.050" Aluminum	38	3000	180	4	1500
HFHS		.058" Steel	3.25	.058" Steel	52	4500	325	4	1500
HFHB		.061" Copper CDA-110	2.56	.061" Copper CDA-110	28	3400	250	4.5	1200
0420	HFH	.060" Aluminum	8	.060" Aluminum	43	5500	285	11	3820
	HFH	.060" Steel	8	.060" Steel	59	7000	480	11	3820
	HFHS	.064" Aluminum	8	.064" Aluminum	32	4000	285	8	2385
	HFHS	.072" Steel	8	.072" Steel	43	6500	480	8	2385
	HFHB	.061" Copper CDA-110	4.35	.061" Copper CDA-110	28	6000	380	5	1908
0518	HFH	.091" Aluminum	16	.091" Aluminum	39	8000	380	22	6280
	HFH	.090" Steel	16	.090" Steel	58	10000	590	22	6280
	HFHS	.087" Aluminum	16	.087" Aluminum	41	5500	380	15	3930
	HFHS	.099" Steel	16	.099" Steel	44	7500	590	15	3930
	HFHB	.126" Copper CDA-110	10.55	.126" Copper CDA-110	32	7500	500	11	3140
0616	HFH	.091" Aluminum	27	.091" Aluminum	39	9000	550	25	9300
	HFH	.090" Steel	27	.090" Steel	58	12000	780	36	9300
	HFHS	.123" Aluminum	27	.123" Aluminum	44	7500	560	25	5810
	HFHS	.099" Steel	27	.099" Steel	44	10500	780	25	5810
	HFHB	.126" Copper CDA-110	21	.126" Copper CDA-110	32	9500	560	18	4650

METRIC	Thread Code	Type	Max. Nut Tightening Torque (N•m)	Test Sheet Thickness and Material	Sheet Hardness HRB	(1) Installation (kN)	Pushout (N)	Torque-out (N•m)	(2) Tensile Strength (kN)
	M5	HFH	1.5 mm Aluminum	4.4	1.5 mm Aluminum	15	13	800	5.4
HFH		1.5 mm Steel	4.4	1.5 mm Steel	65	26	1500	7.6	12.8
HFHS		1.62 mm Aluminum	4.4	1.62 mm Aluminum	35	12.4	800	5.4	7.3
HFHS		1.47 mm Steel	4.4	1.47 mm Steel	54	21.7	1500	6.4	7.3
HFHB		1.5 mm Copper CDA-110	3.47	1.5 mm Copper CDA-110	28	15.6	1115	3.4	5.9
M6	HFH	1.5 mm Aluminum	10	1.5 mm Aluminum	43	29	1270	14	18.1
	HFH	1.5 mm Steel	10	1.5 mm Steel	59	33	1750	14	18.1
	HFHS	1.62 mm Aluminum	10	1.62 mm Aluminum	35	15.4	1270	11	10.3
	HFHS	1.6 mm Steel	10	1.6 mm Steel	45	24.6	1750	11	10.3
	HFHB	1.5 mm Copper CDA-110	5.9	1.5 mm Copper CDA-110	28	25.3	1600	6.7	8.3
M8	HFH	2.3 mm Aluminum	21.7	2.3 mm Aluminum	39	35.6	1700	30	32.9
	HFH	2.3 mm Steel	21.7	2.3 mm Steel	58	44.5	2200	30	32.9
	HFHS	2.23 mm Aluminum	21.7	2.23 mm Aluminum	44	24.4	1700	20	18.8
	HFHS	2.48 mm Steel	21.7	2.48 mm Steel	43	37.8	2100	20	18.8
	HFHB	3.2 mm Copper CDA-110	14.3	3.2 mm Copper CDA-110	32	33	2250	15.3	15.1
M10	HFH	2.3 mm Aluminum	36.6	2.3 mm Aluminum	39	40	2445	36	52.2
	HFH	2.3 mm Steel	36.6	2.3 mm Steel	58	54	3470	49	52.2
	HFHS	2.3 mm Aluminum	36.6	2.3 mm Aluminum	44	33.3	2445	36	29.9
	HFHS	2.3 mm Steel	36.6	2.3 mm Steel	44	46.7	3470	36	29.9
	HFHB	3.2 mm Copper CDA-110	28.5	3.2 mm Copper CDA-110	32	42	2500	25	24

- (1) Installation controlled by proper cavity depth in punch.  
 (2) Head size is adequate to ensure failure in threaded area.

# PERFORMANCE DATA (Continued)

## Type FHL and FHLS Self-clinching Studs

UNIFIED	Thread Code	Max. Nut Tightening Torque (in. lbs.)	Type	Test Sheet Thickness and Material	Sheet Hardness HRB	Installation (lbs.)	Pushout (lbs.)	Torque-out (in. lbs.)	Pull Thru (lbs.)	Pull Thru Test Bushing Hole Size (in.)
	256	2.3	FHL / FHLS	.047" Aluminum	33	700	55	4	230	106
2.3		FHL / FHLS	.045" Steel	54	1200	85	8	425	106	
440	4.0	FHL / FHLS	.047" Aluminum	33	1000	60	5	300	132	
	5.0	FHL / FHLS	.045" Steel	54	1200	105	11	580	132	
632	5.4	FHL / FHLS	.047" Aluminum	33	1000	65	6.5	325	158	
	9.0	FHL / FHLS	.045" Steel	54	1500	110	15	650	158	
832	6.9	FHL / FHLS	.047" Aluminum	33	1200	80	9	350	184	
	15.2	FHL / FHLS	.045" Steel	54	1500	125	18	740	184	
032	9.7	FHL / FHLS	.047" Aluminum	33	2500	115	18	395	210	
	19.4	FHL / FHLS	.045" Steel	54	4500	210	38	800	210	

METRIC	Thread Code	Max. Nut Tightening Torque (N•m)	Type	Test Sheet Thickness and Material	Sheet Hardness HRB	Installation (kN)	Pushout (N)	Torque-out (N•m)	Pull Thru (N)	Pull Thru Test Bushing Hole Size (mm)
	M2.5	0.41	FHL / FHLS	1.2 mm Aluminum	33	3.1	285	0.55	1200	3
0.41		FHL / FHLS	1.1 mm Steel	54	5.3	450	1.1	2250	3	
M3	0.46	FHL / FHLS	1.2 mm Aluminum	33	4.4	285	0.65	1300	3.5	
	0.74	FHL / FHLS	1.1 mm Steel	54	5.3	475	1.25	2500	3.5	
M3.5	0.58	FHL / FHLS	1.2 mm Aluminum	33	4.4	290	0.76	1400	4	
	1.15	FHL / FHLS	1.1 mm Steel	54	6.6	500	1.75	2800	4	
M4	0.75	FHL / FHLS	1.2 mm Aluminum	33	5.3	365	1.1	1550	4.5	
	1.7	FHL / FHLS	1.1 mm Steel	54	6.6	550	2.1	3300	4.5	
M5	1.11	FHL / FHLS	1.2 mm Aluminum	33	11.1	530	2.2	1850	5.5	
	2.25	FHL / FHLS	1.1 mm Steel	54	20	1000	4.4	3750	5.5	

## Type FH4 Self-Clinching Studs<sup>(1)</sup>

UNIFIED	Thread Code	Max. Nut Tightening Torque (in. lbs.)	Test Sheet Thickness and Material	Sheet Hardness HRB Max.	Installation (lbs.)	Pushout (lbs.)	Torque-out (in. lbs.)	Pull Thru (lbs.)
	440	6	.060" Stainless Steel	92	9000	450	16	800
632	11	.060" Stainless Steel	92	9500	540	27	1350	
832	21	.060" Stainless Steel	92	11200	780	58	1800	
032	33	.060" Stainless Steel	92	12000	1050	95	2250	
0420	70	.060" Stainless Steel	92	23000	1600	156	3900	

METRIC	Thread Code	Max. Nut Tightening Torque (N•m)	Test Sheet Thickness and Material	Sheet Hardness HRB Max.	Installation (kN)	Pushout (N)	Torque-out (N•m)	Pull Thru (N)
	M3	.9	1.5 mm Stainless Steel	92	40	2220	1.8	3500
M4	2.1	1.5 mm Stainless Steel	92	50	3210	6.5	8000	
M5	4.3	1.5 mm Stainless Steel	92	53	3575	10.7	10000	
M6	7.2	1.5 mm Stainless Steel	92	71	4200	15.9	14900	

## Type FHP Self-Clinching Studs<sup>(1)</sup>

UNIFIED	Thread Code	Max. Nut Tightening Torque (in. lbs.)	Test Sheet Thickness and Material	Sheet Hardness HRB Max.	Installation (lbs.)	Pushout (lbs.)	Torque-out (in. lbs.)	Pull Thru (lbs.)
	632	11	.045" Stainless Steel	92	9500	670	19.5	940
832	21	.045" Stainless Steel	92	11200	785	37.5	1415	

METRIC	Thread Code	Max. Nut Tightening Torque (N•m)	Test Sheet Thickness and Material	Sheet Hardness HRB Max.	Installation (kN)	Pushout (N)	Torque-out (N•m)	Pull Thru (N)
	M5	4.3	1.14 mm Stainless Steel	92	53	3890	7.35	7320

<sup>(1)</sup> Performance values shown are typical for fasteners properly installed using raised ring tooling in good condition. We recommend replacing installation tooling when the height of the "P" (see page FH-16) dimension is reduced to .005" / 0.13 mm due to wear. Reductions in performance may occur as the height of the protrusion wears. Variations in hole preparation, installation force, and sheet material type, thickness, and hardness will affect both performance and tooling life.

# PERFORMANCE DATA (Continued)

## Type TPS™ Flush-Mounted, Self-Clinching Pilot Pins

UNIFIED	Pin Dia. Code	Test Sheet Material	Sheet Hardness HRB	Installation (lbs.)	Pushout (lbs.)
	125	Aluminum	20	4500	150
		Steel	62	6500	250
	187	Aluminum	18	6500	230
		Steel	60	8000	400
	250	Aluminum	18	7000	270
Steel		62	9000	500	

METRIC	Pin Dia. Code	Test Sheet Material	Sheet Hardness HRB	Installation (kN)	Pushout (kN)
	3mm	Aluminum	22	12	0.56
		Steel	65	22	0.98
	4mm	Aluminum	19	22	0.89
		Steel	66	26.4	1.54
	5mm	Aluminum	18	28.6	1.01
		Steel	60	35.2	1.76
	6mm	Aluminum	18	30.8	1.1
Steel		62	39.6	2.1	

## Type HFE Self-Clinching Studs

UNIFIED	Thread Code	Max. Nut Tightening Torque (ft. lbs.)	Test Sheet Thickness and Material (in.)	Sheet Hardness HRB	Installation (lbs.) (1)	Pushout (lbs.)	Torque-out (in. lbs.)	Pull Thru (lbs.)	Test Bushing Hole Size For Pull Thru Tests
	032	3.25	.040" Aluminum	27	7500	170	60	1900	.279
			.040" Cold-rolled Steel	67	9500	300	60	2200	
	0420	8	.040" Aluminum	27	8000	180	120	3200	.335
			.040" Cold-rolled Steel	67	13500	340	130	3600	
	0518	16	.060" Aluminum	22	9000	275	240	6000	.407
.060" Cold-rolled Steel			65	15500	575	290	6400		

METRIC	Thread Code	Max. Nut Tightening Torque (N•m)	Test Sheet Thickness and Material (mm)	Sheet Hardness HRB	Installation (kN) (1)	Pushout (N)	Torque-out (N•m)	Pull Thru (kN)	Test Bushing Hole Size For Pull Thru Tests
	M5	4.4	1 mm Aluminum	27	37.7	690	8.1	9.7	7.4
			1 mm Cold-rolled Steel	67	51.1	1350	8.1	10.6	
	M6	10	1 mm Aluminum	27	39	750	11.8	14.2	8.2
			1 mm Cold-rolled Steel	67	60	1400	14.4	15.5	
	M8	21.7	1.5 mm Aluminum	22	42	1230	23.5	25	10.3
1.5 mm Cold-rolled Steel			65	71.1	2400	33.9	27.5		

(1) Installation controlled by proper cavity depth in punch.