



RIGHT ANGLE

CLINCH

FASTENERS

BULLETIN

The *edge* you've been waiting for™



RA
1005

PEM® R'ANGLE® RIGHT ANGLE CLINCH FASTENER – TYPES RAA™ AND RAS™

Self-clinching PEM® R'ANGLE® fasteners provide you with strong right angle attachment points in sheets as thin as .040" / 1 mm.

R'ANGLE fasteners are cost-effective replacements for:

- ***bent edge tabs***
- ***bent center tabs***
- ***bent flanges***
- ***angle brackets***
- ***tack welds***
- ***loose hardware***

Simply press this fastener into a properly sized rectangular mounting hole. It is held permanently in the sheet or panel using the same high-performance, self-clinching technology that our products have employed since 1942.

Now you can securely attach another sheet or component perpendicular to the sheet in which the R'ANGLE fastener is installed. For Type RAA, attachment is easily made using thread forming screws resulting in a thread fit which resists vibration and has excellent torque resistance.* Type RAS fasteners are threaded and attachment is simply made using a standard screw. For either type, the holding power of the fastener is unaffected by the repeated removal and reinstallation of the screw.

PEM® R'ANGLE fasteners provide many advantages over bent tabs and flanges, including:

- ***more predictable designs***
- ***material savings***
- ***tighter design control***
- ***improved shielding characteristics***
- ***reduction of loose hardware***
- ***fewer assembly steps***
- ***unmarred panel surfaces***

* As thread forming screws do not generate metal residue, they are widely used in electrical and electronic assemblies.



Type RAA (Aluminum) For
Thread-forming Screws

Patented



Type RAS (Steel)
Threaded



Part Number Designation



Type &
Material

Thread
Form
Screw Size
or Thread
Code

Height
Code

Length
Code

Finish
Code
(if applicable)

TYPE RAA - ALUMINUM SELF-TAPPING RIGHT ANGLE FASTENER

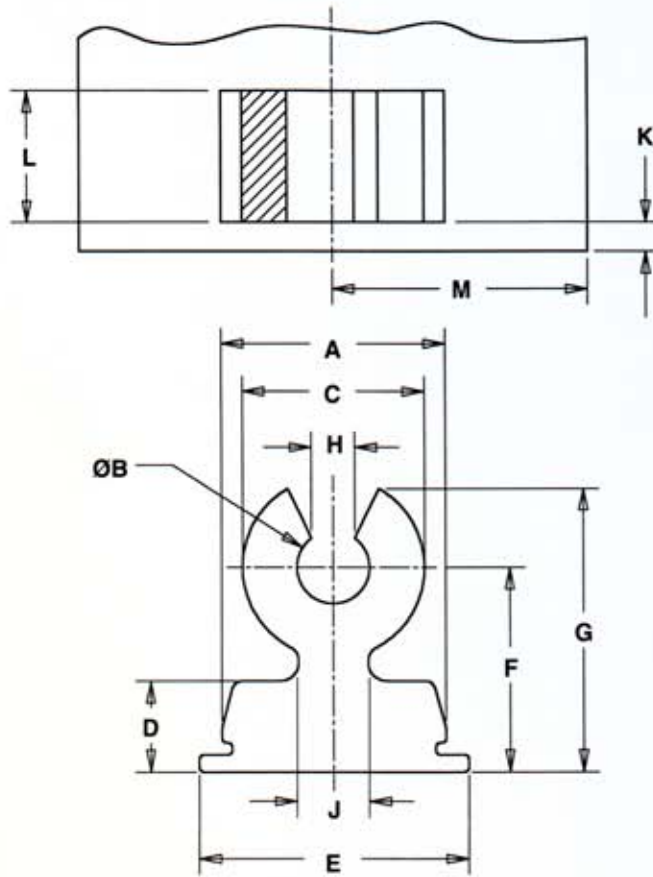

Metric part can be identified by flat top



All dimensions are in inches.

UNIFIED	Thread Form Screw Size	Type	Material	Screw Size Code	Height Code	Length Code	Length L ±.003	Min. Sheet Thickness	Hole Size In Sheet +.002 -.001	A ±.003	ØB ±.004	C Nom.	D Nom.	E ±.006	Height F ±.006	G Nom.	H ±.007	J Nom.	Min. Part Face to Edge K	Min. Dist. Hole C/L To Edge M
	#4-40	RA	A	4	9	6	.183	.040	.312 x .187 .312 x .250	.308	.100	.250	.125	.368	.281	.389	.054	.096	.040	.35 .36
#6-32	RA	A	6	10	8	.246	.040	.375 x .250 .375 x .312	.371	.123	.300	.125	.431	.312	.442	.066	.141	.040	.50 .55	
					10	.308														
#8-32	RA	A	8	12	9	.277	.040	.406 x .281 .406 x .375	.402	.145	.350	.125	.462	.375	.525	.078	.157	.040	.58 .65	
					12	.371														

All dimensions are in millimeters.

METRIC	Thread Form Screw Size	Type	Material	Screw Size Code	Height Code	Length Code	Length L ±0.08	Min. Sheet Thickness	Hole Size In Sheet +0.05 -.0.03	A ±0.08	ØB ±0.1	C Nom.	D Nom.	E ±0.15	Height F ±0.15	G Nom.	H ±0.18	J Nom.	Min. Part Face to Edge K	Min. Dist. Hole C/L To Edge M
	M3 x 0.5	RA	A	M3	7	4	3.9	1	8 x 4	7.9	2.77	6.35	3.18	9.42	7	9.27	1.5	2.87	1.02	9.1 10.7
6						5.9														
M4 x 0.7	RA	A	M4	9	7	6.9	1	10 x 7	9.9	3.68	8.89	3.18	11.43	9	12.19	1.97	4.06	1.02	14.7 16.3	
					9	8.9														

TYPE RAS - STEEL THREADED RIGHT ANGLE FASTENER

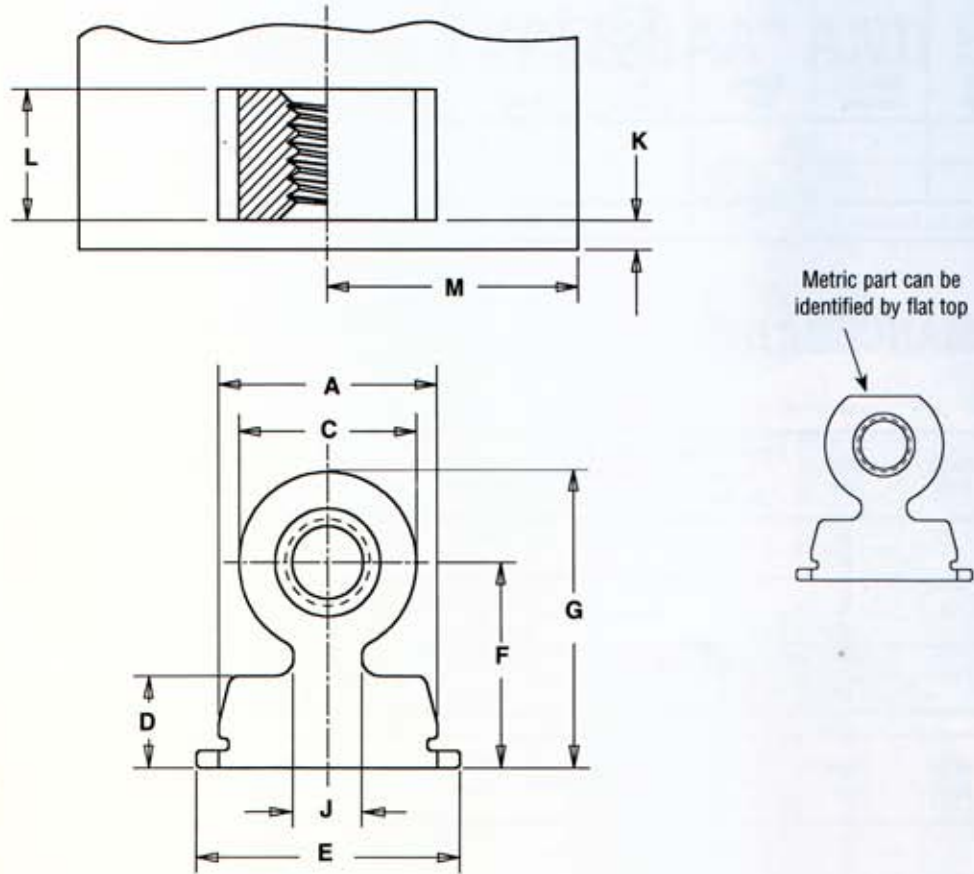

All dimensions are in inches.

UNIFIED	Thread Size	Type	Material	Thread Code	Height Code	Length Code	Length L ±.003	Min. Sheet Thickness	Hole Size In Sheet +.002 -.001	A ±.003	C Nom.	D Nom.	E ±.006	Height F ±.006	G Nom.	J Nom.	Min. Part Face to Edge K	Min. Dist. Hole C/L To Edge M
		.112-40 (#4-40)	RA	S	440	9	4	.121	.040	.312 x .125	.308	.250	.125	.370	.281	.406	.096	.040
6							.183	.312 x .187		.35								
8							.246	.312 x .250		.43								
138-32 (#6-32)		RA	S	632	10	4	.121	.040	.375 x .125	.371	.300	.125	.433	.312	.462	.141	.040	.35
						8	.246		.375 x .250									.50
						10	.308		.375 x .312									.55
164-32 (#8-32)		RA	S	832	12	6	.183	.040	.406 x .187	.402	.350	.125	.464	.375	.550	.157	.040	.40
						9	.277		.406 x .281									.58
						12	.371		.406 x .375									.65

All dimensions are in millimeters.

METRIC	Thread Size x Pitch	Type	Material	Thread Code	Height Code	Length Code	Length L ±0.08	Min. Sheet Thickness	Hole Size In Sheet +0.05 -.0.03	A ±0.08	C Nom.	D Nom.	E ±0.15	Height F ±0.15	G Nom.	J Nom.	Min. Part Face to Edge K	Min. Dist. Hole C/L To Edge M
	M3 x 0.5	RA	S	M3	M3	7	3	2.9	1	8 x 3	7.9	6.35	3.18	9.47	7	9.78	2.87	1.02
4							3.9	8 x 4		9.1								
6							5.9	8 x 6		10.7								
4							3.9	10 x 4		10								
7							6.9	10 x 7		14.7								
9							8.9	10 x 9		16.3								

MATERIAL & FINISH SPECIFICATIONS

Type	Threads	Fastener Materials		Standard Finishes		For Use in Sheet Hardness:	
	Internal, ANSI B1.1, 2B ANS/ASME B1.13M, 6H	6061-T6 Aluminum	Sintered Steel	Zinc Per ASTM B 633 SC1 (5µm), Type III, Colorless	Natural	45 or Less on the Rockwell "B" scale	60 or Less on the Rockwell "B" scale
RAA		*			*	*	
RAS	*		*	*			*
Part Number Codes for Finishes				ZI	None		

PERFORMANCE DATA⁽¹⁾

Type RAA

UNIFIED	Screw Size Code	Height Code	Length Code	Thread Forming Torque (in. lbs.)	Max. Rec. Tightening Torque (in. lbs.)	Test Sheet Material	Installation (lbs.)	Pushout (lbs.)	Max. Load (lbs.) (2)	Pull Thru (lbs.)
	4	9	6	3	6	5052-H34	1800	140	8	80
8			4	10	Aluminum	1800	180	13	80	
6	10	8	5.5	11	5052-H34	2500	175	12	85	
		10	5.5	17	Aluminum	2500	235	16	85	
8	12	9	6.5	18	5052-H34	3100	205	13	105	
		12	8.0	20	Aluminum	3100	255	21	105	

METRIC	Screw Size Code	Height Code	Length Code	Thread Forming Torque (N•m)	Max. Rec. Tightening Torque (N•m)	Test Sheet Material	Installation (kN)	Pushout (N)	Max. Load (N) (2)	Pull Thru (N)
	M3	7	4	.17	.56	5052-H34	7.1	556	27	356
6			.23	1.02	Aluminum	7.1	756	44	356	
M4	9	7	.56	2.26	5052-H34	13.3	890	76	423	
		9	.56	2.83	Aluminum	13.3	1045	107	423	

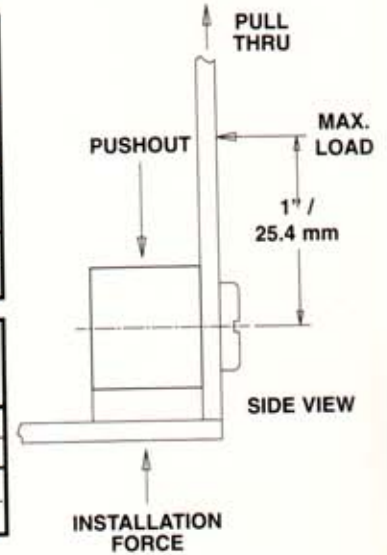

Type RAS

UNIFIED	Thread Code	Height Code	Length Code	Test Sheet Material									
				5052-H34 Aluminum					Cold-rolled Steel				
				Max. Rec. Tightening Torque (in. lbs.)	Installation (lbs.)	Pushout (lbs.)	Max. Load (lbs.) (2)	Pull Thru (lbs.)	Max. Rec. Tightening Torque (in. lbs.)	Installation (lbs.)	Pushout (lbs.)	Max. Load (lbs.) (2)	Pull Thru (lbs.)
440	9	4	13	1800	100	7	80	16	2400	180	9	80	
		6	17	1800	145	8	80	17	2400	260	9	80	
		8	17	2100	180	13	80	17	3000	315	15	80	
	632	10	4	20	2000	100	7	85	20	2500	190	9	85
			8	21	2500	190	12	85	26	3200	335	16	85
			10	21	2800	230	16	85	26	4000	385	20	85
832	12	6	20	2400	140	15	100	27	3200	260	11	100	
		9	23	3300	195	16	100	29	4200	345	20	100	
		12	30	3500	260	20	100	35	4700	420	27	100	

METRIC	Thread Code	Height Code	Length Code	Test Sheet Material									
				5052-H34 Aluminum					Cold-rolled Steel				
				Max. Rec. Tightening Torque (N•m)	Installation (kN)	Pushout (N)	Max. Load (N) (2)	Pull Thru (N)	Max. Rec. Tightening Torque (N•m)	Installation (kN)	Pushout (N)	Max. Load (N) (2)	Pull Thru (N)
M3	7	3	1.47	8	423	36	356	2.26	10.7	778	40	356	
		4	1.92	8	534	36	356	2.71	10.7	1001	40	356	
		6	2.15	9.3	756	58	356	2.71	13.3	1312	67	356	
M4	9	4	2.15	8.9	556	53	423	3.28	11.6	956	44	423	
		7	2.6	13.3	890	76	423	4.07	16	1512	80	423	
		9	2.83	13.3	1112	93	423	4.52	18.7	1846	116	423	

(1) The installation, pushout, and side-load values reported are averages when all installation specifications and procedures are followed. Variations in mounting hole size, sheet material and installation procedure will affect this data. Performance testing of this product in your application is recommended. We will be happy to provide samples for this purpose.

(2) 1" / 25.4 mm from screw centerline.

INSTALLATION

1. Punch a properly sized rectangular mounting hole in the sheet. Do not perform any secondary operations such as deburring.
2. Place the fastener through the mounting hole and into the anvil as shown in the drawing to the right.
3. With the punch and anvil surfaces parallel, apply a squeezing force until the bottom of the fastener becomes flush with the sheet.

* NOTE: The punch must be large enough to cover the entire base of the fastener to ensure proper installation.

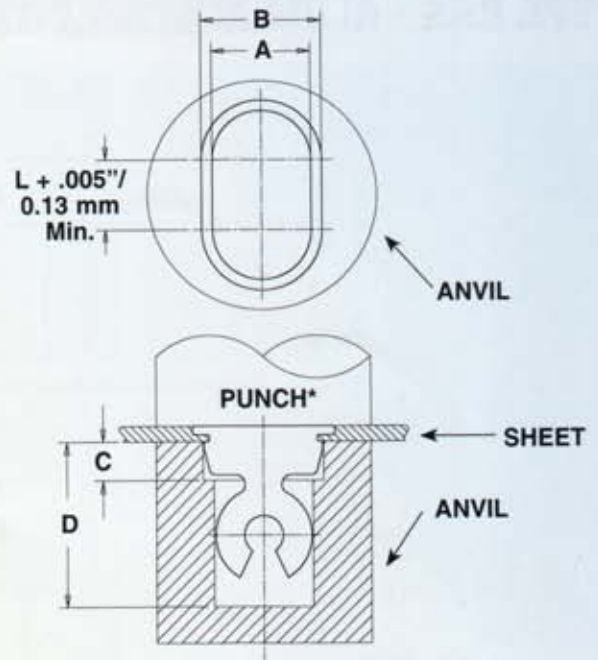

Installation tooling is available from Penn Engineering.

Anvil Dimensions

UNIFIED	Screw or Thread Size Code	Anvil Dimensions (in.)				Anvil Part Number
		A ±.001	B ±.001	C ±.005	D Min.	
	4 / 440	.257	.313	.100	.425	8002711
	6 / 632	.307	.376	.100	.500	8002712
	8 / 832	.357	.407	.100	.575	8003642

METRIC	Screw or Thread Size Code	Anvil Dimensions (mm)				Anvil Part Number
		A ±0.03	B ±0.03	C ±0.1	D Min.	
	M3	6.53	8.02	2.54	10.8	8002713
	M4	9.07	10.03	2.54	12.7	8002714

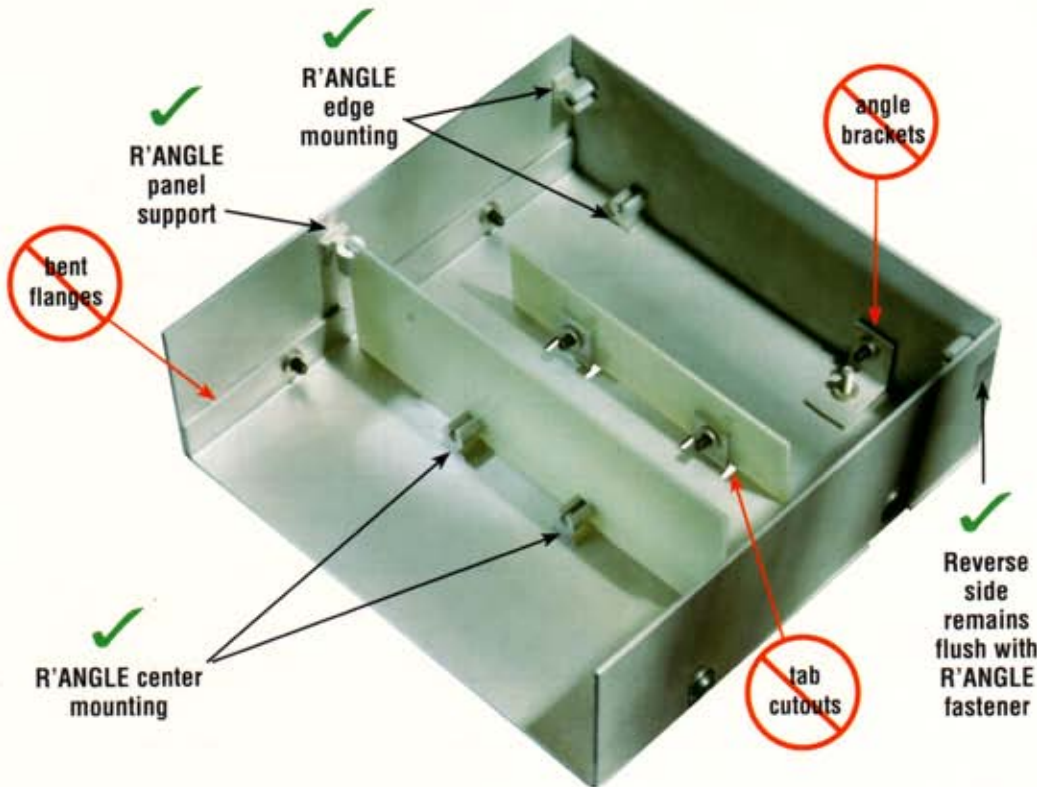

For mounting to P.C. Boards, ask about ReelFast™ SMT R'ANGLE fasteners which are attached using conventional surface mount techniques.

RoHS compliance information can be found on our web site.

Specifications subject to change without notice.

PennEngineering®



Corporate Office:
5190 Old Easton Road
Danboro, PA 18916 USA
E-mail: info@pemnet.com
Toll Free: 800-342-5736 (USA Only)
Tel: 215-766-8853 • Fax: 215-766-3633

PEM U.K. And Europe:
Kirk Sandall Industrial Estate
Doncaster, South Yorkshire
DN3 1QR, England
E-mail: uk@pemnet.com
Tel: 01302 893100 • Fax: 01302 885341

PEM Asia/Pacific:
Citipoint Industrial Complex
152 Paya Lebar Road #03-06
Singapore 409020
E-mail: singapore@pemnet.com
Tel: 6 745 0660 • Fax: 6 745 2400

Visit our PEMNET™ Resource Center at www.pemnet.com

CAGE-46384